



# REALTEK

**ALC662**  
**(ALC662-GR, ALC662-VC-GR)**

## **5.1 CHANNEL HIGH DEFINITION AUDIO CODEC**

### **DATASHEET**

**Rev. 1.1**  
**15 March 2008**  
**Track ID: JATR-1076-21**



**Realtek Semiconductor Corp.**

No. 2, Innovation Road II, Hsinchu Science Park, Hsinchu 300, Taiwan

Tel.: +886-3-578-0211. Fax: +886-3-577-6047

[www.realtek.com.tw](http://www.realtek.com.tw)

**COPYRIGHT**

©2008 Realtek Semiconductor Corp. All rights reserved. No part of this document may be reproduced, transmitted, transcribed, stored in a retrieval system, or translated into any language in any form or by any means without the written permission of Realtek Semiconductor Corp.

**DISCLAIMER**

Realtek provides this document “as is”, without warranty of any kind, neither expressed nor implied, including, but not limited to, the particular purpose. Realtek may make improvements and/or changes in this document or in the product described in this document at any time. This document could include technical inaccuracies or typographical errors.

**TRADEMARKS**

Realtek is a trademark of Realtek Semiconductor Corporation. Other names mentioned in this document are trademarks/registered trademarks of their respective owners.

**USING THIS DOCUMENT**

This document is intended for the hardware and software engineer’s general information on the Realtek ALC662 codec IC.

Though every effort has been made to ensure that this document is current and accurate, more information may have become available subsequent to the production of this guide. In that event, please contact your Realtek representative for additional information that may help in the development process.

**REVISION HISTORY**

Revision	Release Date	Summary
1.0	2007/01/15	First release for ALC662.
1.1	2008/03/15	Added ALC662-VC (ALC662 C version) data. Update passband ripple information in Table 82, page 63.

## Table of Contents

<b>1. GENERAL DESCRIPTION</b> .....	<b>1</b>
<b>2. FEATURES</b> .....	<b>2</b>
2.1. HARDWARE FEATURES .....	2
2.2. SOFTWARE FEATURES.....	3
2.3. UPGRADED FEATURES FOR FUTURE WLP (ALC662-VC).....	3
<b>3. SYSTEM APPLICATIONS</b> .....	<b>3</b>
<b>4. BLOCK DIAGRAM</b> .....	<b>4</b>
<b>5. PIN ASSIGNMENTS</b> .....	<b>5</b>
5.1. PACKAGE AND VERSION IDENTIFICATION .....	5
<b>6. PIN DESCRIPTIONS</b> .....	<b>6</b>
6.1. DIGITAL I/O PINS .....	6
6.2. ANALOG I/O PINS .....	6
6.3. FILTER/REFERENCE.....	7
6.4. POWER/GROUND.....	7
6.5. NC (NOT CONNECTED) PINS .....	7
<b>7. HIGH DEFINITION AUDIO LINK PROTOCOL</b> .....	<b>8</b>
7.1. LINK SIGNALS.....	8
7.1.1. <i>Signal Definitions</i> .....	9
7.1.2. <i>Signaling Topology</i> .....	10
7.2. FRAME COMPOSITION .....	11
7.2.1. <i>Outbound Frame – Single SDO</i> .....	11
7.2.2. <i>Outbound Frame – Multiple SDOs</i> .....	12
7.2.3. <i>Inbound Frame – Single SDI</i> .....	13
7.2.4. <i>Inbound Frame – Multiple SDIs</i> .....	14
7.2.5. <i>Variable Sample Rates</i> .....	14
7.3. RESET AND INITIALIZATION .....	17
7.3.1. <i>Link Reset</i> .....	17
7.3.2. <i>Codec Reset</i> .....	18
7.3.3. <i>Codec Initialization Sequence</i> .....	19
7.4. VERB AND RESPONSE FORMAT .....	19
7.4.1. <i>Command Verb Format</i> .....	19
7.4.2. <i>Response Format</i> .....	22
7.5. POWER MANAGEMENT.....	22
7.5.1. <i>System Power State Definitions</i> .....	22
7.5.2. <i>Power Controls in NID 01h</i> .....	23
7.5.3. <i>Powered Down Conditions</i> .....	23
<b>8. SUPPORTED VERBS AND PARAMETERS</b> .....	<b>24</b>
8.1. VERB – GET PARAMETERS (VERB ID=F00H).....	24
8.1.1. <i>Parameter – Vendor ID (Verb ID=F00h, Parameter ID=00h)</i> .....	24
8.1.2. <i>Parameter – Revision ID (Verb ID=F00h, Parameter ID=02h)</i> .....	24
8.1.3. <i>Parameter – Subordinate Node Count (Verb ID=F00h, Parameter ID=04h)</i> .....	25
8.1.4. <i>Parameter – Function Group Type (Verb ID=F00h, Parameter ID=05h)</i> .....	25
8.1.5. <i>Parameter – Audio Function Capabilities (Verb ID=F00h, Parameter ID=08h)</i> .....	25

8.1.6.	Parameter – Audio Widget Capabilities (Verb ID=F00h, Parameter ID=09h)	26
8.1.7.	Parameter – Supported PCM Size, Rates (Verb ID=F00h, Parameter ID=0Ah)	27
8.1.8.	Parameter – Supported Stream Formats (Verb ID=F00h, Parameter ID=0Bh)	28
8.1.9.	Parameter – Pin Capabilities (Verb ID=F00h, Parameter ID=0Ch)	28
8.1.10.	Parameter – Amplifier Capabilities (Verb ID=F00h, Input Amplifier Parameter ID=0Dh)	29
8.1.11.	Parameter – Amplifier Capabilities (Verb ID=F00h, Output Amplifier Parameter ID=12h)	29
8.1.12.	Parameter – Connect List Length (Verb ID=F00h, Parameter ID=0Eh)	30
8.1.13.	Parameter – Supported Power States (Verb ID=F00h, Parameter ID=0Fh)	30
8.1.14.	Parameter – Processing Capabilities (Verb ID=F00h, Parameter ID=10h)	30
8.1.15.	Parameter – GPIO Capabilities (Verb ID=F00h, Parameter ID=11h)	31
8.1.16.	Parameter – Volume Knob Capabilities (Verb ID=F00h, Parameter ID=13h)	31
8.2.	VERB – GET CONNECTION SELECT CONTROL (VERB ID=F01H)	32
8.3.	VERB – SET CONNECTION SELECT (VERB ID=701H)	32
8.4.	VERB – GET CONNECTION LIST ENTRY (VERB ID=F02H)	33
8.5.	VERB – GET PROCESSING STATE (VERB ID=F03H)	36
8.6.	VERB – SET PROCESSING STATE (VERB ID=703H)	37
8.7.	VERB – GET COEFFICIENT INDEX (VERB ID=DH)	37
8.8.	VERB – SET COEFFICIENT INDEX (VERB ID=5H)	37
8.9.	VERB – GET PROCESSING COEFFICIENT (VERB ID=CH)	38
8.10.	VERB – SET PROCESSING COEFFICIENT (VERB ID=4H)	38
8.11.	VERB – GET AMPLIFIER GAIN (VERB ID=BH)	39
8.12.	VERB – SET AMPLIFIER GAIN (VERB ID=3H)	42
8.13.	VERB – GET CONVERTER FORMAT (VERB ID=AH)	43
8.14.	GET CONVERTER FORMAT SUPPORT	43
8.15.	VERB – SET CONVERTER FORMAT (VERB ID=2H)	44
8.16.	VERB – GET POWER STATE (VERB ID=F05H)	45
8.17.	VERB – SET POWER STATE (VERB ID=705H)	45
8.18.	VERB – GET CONVERTER STREAM, CHANNEL (VERB ID=F06H)	46
8.19.	VERB – SET CONVERTER STREAM, CHANNEL (VERB ID=706H)	46
8.20.	VERB – GET PIN WIDGET CONTROL (VERB ID=F07H)	47
8.21.	VERB – SET PIN WIDGET CONTROL (VERB ID=707H)	48
8.22.	VERB – GET UNSOLICITED RESPONSE CONTROL (VERB ID=F08H)	49
8.23.	VERB – SET UNSOLICITED RESPONSE CONTROL (VERB ID=708H)	49
8.24.	VERB – GET PIN SENSE (VERB ID=F09H)	50
8.25.	VERB – EXECUTE PIN SENSE (VERB ID=709H)	50
8.26.	VERB – GET CONFIGURATION DEFAULT (VERB ID=F1CH/F1DH/F1EH/F1FH)	51
8.27.	VERB – SET CONFIGURATION DEFAULT BYTES 0, 1, 2, 3 (VERB ID=71CH/71DH/71EH/71FH FOR BYTES 0, 1, 2, 3)	51
8.28.	VERB – GET BEEP GENERATOR (VERB ID=F0AH)	52
8.29.	VERB – SET BEEP GENERATOR (VERB ID=70AH)	52
8.30.	VERB – GET GPIO DATA (VERB ID= F15H)	53
8.31.	VERB – SET GPIO DATA (VERB ID= 715H)	53
8.32.	VERB – GET GPIO ENABLE MASK (VERB ID=F16H)	54
8.33.	VERB – SET GPIO ENABLE MASK (VERB ID=716H)	54
8.34.	VERB – GET GPIO DIRECTION (VERB ID=F17H)	55
8.35.	VERB – SET GPIO DIRECTION (VERB ID=717H)	55
8.36.	VERB – GET GPIO UNSOLICITED RESPONSE ENABLE MASK (VERB ID=F19H)	56
8.37.	VERB – SET GPIO UNSOLICITED RESPONSE ENABLE MASK (VERB ID=719H)	56
8.38.	VERB – GET DIGITAL CONVERTER CONTROL 1 & CONTROL 2 (VERB ID= F0DH, F0EH)	57
8.39.	VERB – SET DIGITAL CONVERTER CONTROL 1 & CONTROL 2 (VERB ID=70DH, 70EH)	58
8.40.	VERB – GET SUBSYSTEM ID [31:0] (VERB ID=F20H/F21H/D22H/F23H)	59
8.41.	VERB – SET SUBSYSTEM ID [31:0] (VERB ID=723H FOR [31:24], 722H FOR [23:16], 721H FOR [15:8], 720H FOR [7:0])	59
8.42.	VERB – GET EAPD CONTROL (VERB ID=F0CH)	60
8.43.	VERB – SET EAPD CONTROL (VERB ID=70CH)	60
8.44.	VERB – FUNCTION RESET (VERB ID=7FFH)	61

---

<b>9.</b>	<b>ELECTRICAL CHARACTERISTICS .....</b>	<b>62</b>
9.1.	DC CHARACTERISTICS.....	62
9.1.1.	<i>Absolute Maximum Ratings</i> .....	62
9.1.2.	<i>Threshold Voltage</i> .....	62
9.1.3.	<i>Digital Filter Characteristics</i> .....	63
9.1.4.	<i>S/PDIF Output Characteristics</i> .....	63
9.2.	AC CHARACTERISTICS.....	64
9.2.1.	<i>Link Reset and Initialization Timing</i> .....	64
9.2.2.	<i>Link Timing Parameters at the Codec</i> .....	65
9.2.3.	<i>S/PDIF Output Timing</i> .....	66
9.2.4.	<i>Test Mode</i> .....	66
9.3.	ANALOG PERFORMANCE.....	67
<b>10.</b>	<b>APPLICATION CIRCUITS .....</b>	<b>68</b>
10.1.	FILTER CONNECTION .....	68
10.2.	ONBOARD FRONT PANEL HEADER CONNECTION AND FRONT PANEL I/O .....	69
10.3.	ANALOG INPUT/OUTPUT CONNECTION .....	70
10.4.	OPTIONAL S/PDIF OUTPUT.....	70
<b>11.</b>	<b>MECHANICAL DIMENSIONS.....</b>	<b>71</b>
11.1.	MECHANICAL DIMENSIONS NOTES .....	72
<b>12.</b>	<b>ORDERING INFORMATION.....</b>	<b>73</b>

---

## List of Tables

TABLE 1.	DIGITAL I/O PINS.....	6
TABLE 2.	ANALOG I/O PINS.....	6
TABLE 3.	FILTER/REFERENCE.....	7
TABLE 4.	POWER/GROUND.....	7
TABLE 5.	NOT CONNECTED PINS.....	7
TABLE 6.	LINK RESET#.....	9
TABLE 7.	HDA SIGNAL DEFINITIONS.....	9
TABLE 8.	DEFINED SAMPLE RATE AND TRANSMISSION RATE.....	15
TABLE 9.	48KHZ VARIABLE RATE OF DELIVERY TIMING.....	15
TABLE 10.	44.1KHZ VARIABLE RATE OF DELIVERY TIMING.....	16
TABLE 11.	40-BIT COMMANDS IN 4-BIT VERB FORMAT.....	19
TABLE 12.	40-BIT COMMANDS IN 12-BIT VERB FORMAT.....	19
TABLE 13.	SUPPORTED COMMANDS.....	20
TABLE 14.	SUPPORTED PARAMETERS.....	21
TABLE 15.	SOLICITED RESPONSE FORMAT.....	22
TABLE 16.	UNSOLICITED RESPONSE FORMAT.....	22
TABLE 17.	SYSTEM POWER STATE DEFINITIONS.....	22
TABLE 18.	POWER CONTROLS IN NID 01H.....	23
TABLE 19.	POWERED DOWN CONDITIONS.....	23
TABLE 20.	VERB – GET PARAMETERS (VERB ID=F00H).....	24
TABLE 21.	PARAMETER – VENDOR ID (VERB ID=F00H, PARAMETER ID=00H).....	24
TABLE 22.	PARAMETER – REVISION ID (VERB ID=F00H, PARAMETER ID=02H).....	24
TABLE 23.	PARAMETER – SUBORDINATE NODE COUNT (VERB ID=F00H, PARAMETER ID=04H).....	25
TABLE 24.	PARAMETER – FUNCTION GROUP TYPE (VERB ID=F00H, PARAMETER ID=05H).....	25
TABLE 25.	PARAMETER – AUDIO FUNCTION CAPABILITIES (VERB ID=F00H, PARAMETER ID=08H).....	25
TABLE 26.	PARAMETER – AUDIO WIDGET CAPABILITIES (VERB ID=F00H, PARAMETER ID=09H).....	26
TABLE 27.	PARAMETER – SUPPORTED PCM SIZE, RATES (VERB ID=F00H, PARAMETER ID=0AH).....	27
TABLE 28.	PARAMETER – SUPPORTED STREAM FORMATS (VERB ID=F00H, PARAMETER ID=0BH).....	28
TABLE 29.	PARAMETER – PIN CAPABILITIES (VERB ID=F00H, PARAMETER ID=0CH).....	28
TABLE 30.	PARAMETER – AMPLIFIER CAPABILITIES (VERB ID=F00H, INPUT AMPLIFIER PARAMETER ID=0DH).....	29
TABLE 31.	PARAMETER – AMPLIFIER CAPABILITIES (VERB ID=F00H, OUTPUT AMPLIFIER PARAMETER ID=12H).....	29
TABLE 32.	PARAMETER – CONNECT LIST LENGTH (VERB ID=F00H, PARAMETER ID=0EH).....	30
TABLE 33.	PARAMETER – SUPPORTED POWER STATES (VERB ID=F00H, PARAMETER ID=0FH).....	30
TABLE 34.	PARAMETER – PROCESSING CAPABILITIES (VERB ID=F00H, PARAMETER ID=10H).....	30
TABLE 35.	PARAMETER – GPIO CAPABILITIES (VERB ID=F00H, PARAMETER ID=11H).....	31
TABLE 36.	PARAMETER – VOLUME KNOB CAPABILITIES (VERB ID=F00H, PARAMETER ID=13H).....	31
TABLE 37.	VERB – GET CONNECTION SELECT CONTROL (VERB ID=F01H).....	32
TABLE 38.	VERB – SET CONNECTION SELECT (VERB ID=701H).....	32
TABLE 39.	VERB – GET CONNECTION LIST ENTRY (VERB ID=F02H).....	33
TABLE 40.	VERB – GET PROCESSING STATE (VERB ID=F03H).....	36
TABLE 41.	VERB – SET PROCESSING STATE (VERB ID=703H).....	37
TABLE 42.	VERB – GET COEFFICIENT INDEX (VERB ID=DH).....	37
TABLE 43.	VERB – SET COEFFICIENT INDEX (VERB ID=5H).....	37
TABLE 44.	VERB – GET PROCESSING COEFFICIENT (VERB ID=CH).....	38
TABLE 45.	VERB – SET PROCESSING COEFFICIENT (VERB ID=4H).....	38
TABLE 46.	VERB – GET AMPLIFIER GAIN (VERB ID=BH).....	39
TABLE 47.	VERB – SET AMPLIFIER GAIN (VERB ID=3H).....	42
TABLE 48.	VERB – GET CONVERTER FORMAT (VERB ID=AH).....	43
TABLE 49.	GET CONVERTER FORMAT SUPPORT.....	43
TABLE 50.	VERB – SET CONVERTER FORMAT (VERB ID=2H).....	44
TABLE 51.	VERB – GET POWER STATE (VERB ID=F05H).....	45
TABLE 52.	VERB – SET POWER STATE (VERB ID=705H).....	45

TABLE 53. VERB – GET CONVERTER STREAM, CHANNEL (VERB ID=F06H) .....	46
TABLE 54. VERB – SET CONVERTER STREAM, CHANNEL (VERB ID=706H) .....	46
TABLE 55. VERB – GET PIN WIDGET CONTROL (VERB ID=F07H) .....	47
TABLE 56. VERB – SET PIN WIDGET CONTROL (VERB ID=707H) .....	48
TABLE 57. VERB – GET UNSOLICITED RESPONSE CONTROL (VERB ID=F08H) .....	49
TABLE 58. VERB – SET UNSOLICITED RESPONSE CONTROL (VERB ID=708H) .....	49
TABLE 59. VERB – GET PIN SENSE (VERB ID=F09H).....	50
TABLE 60. VERB – EXECUTE PIN SENSE (VERB ID=709H).....	50
TABLE 61. VERB – GET CONFIGURATION DEFAULT (VERB ID=F1Ch/F1Dh/F1Eh/F1Fh).....	51
TABLE 62. VERB – SET CONFIGURATION DEFAULT BYTES 0, 1, 2, 3 (VERB ID=71Ch/71Dh/71Eh/71Fh FOR BYTES 0, 1, 2, 3).....	51
TABLE 63. VERB – GET BEEP GENERATOR (VERB ID= F0Ah) .....	52
TABLE 64. VERB – SET BEEP GENERATOR (VERB ID= 70Ah) .....	52
TABLE 65. VERB – GET GPIO DATA (VERB ID= F15h).....	53
TABLE 66. VERB – SET GPIO DATA (VERB ID= 715h).....	53
TABLE 67. VERB – GET GPIO ENABLE MASK (VERB ID= F16h).....	54
TABLE 68. VERB – SET GPIO ENABLE MASK (VERB ID=716h) .....	54
TABLE 69. VERB – GET GPIO DIRECTION (VERB ID=F17h).....	55
TABLE 70. VERB – SET GPIO DIRECTION (VERB ID=717h) .....	55
TABLE 71. VERB – GET GPIO UNSOLICITED RESPONSE ENABLE MASK (VERB ID=F19h) .....	56
TABLE 72. VERB – SET GPIO UNSOLICITED RESPONSE ENABLE MASK (VERB ID=719h).....	56
TABLE 73. VERB – GET DIGITAL CONVERTER CONTROL 1 & CONTROL 2 (VERB ID= F0Dh, F0Eh) .....	57
TABLE 74. VERB – SET DIGITAL CONVERTER CONTROL 1 & CONTROL 2 (VERB ID=70Dh, 70Eh).....	58
TABLE 75. VERB – GET SUBSYSTEM ID [31:0] (VERB ID=F20h/F21h/F22h/F23h).....	59
TABLE 76. VERB – SET SUBSYSTEM ID [31:0] (VERB ID=723h FOR [31:24], 722h FOR [23:16], 721h FOR [15:8], 720h FOR [7:0]) .....	59
TABLE 77. VERB – GET EAPD CONTROL (VERB ID=F0Ch).....	60
TABLE 78. VERB – SET EAPD CONTROL (VERB ID=70Ch).....	60
TABLE 79. VERB – FUNCTION RESET (VERB ID=7FFh) .....	61
TABLE 80. ABSOLUTE MAXIMUM RATINGS .....	62
TABLE 81. THRESHOLD VOLTAGE.....	62
TABLE 82. DIGITAL FILTER CHARACTERISTICS .....	63
TABLE 83. S/PDIF OUTPUT CHARACTERISTICS.....	63
TABLE 84. LINK RESET AND INITIALIZATION TIMING.....	64
TABLE 85. LINK TIMING PARAMETERS AT THE CODEC .....	65
TABLE 86. S/PDIF OUTPUT TIMING .....	66
TABLE 87. ANALOG PERFORMANCE .....	67
TABLE 88. ORDERING INFORMATION .....	73

---

## List of Figures

---

FIGURE 1. BLOCK DIAGRAM .....	4
FIGURE 2. PIN ASSIGNMENTS .....	5
FIGURE 3. HDA LINK PROTOCOL.....	8
FIGURE 4. BIT TIMING.....	9
FIGURE 5. SIGNALING TOPOLOGY .....	10
FIGURE 6. SDO OUTBOUND FRAME.....	11
FIGURE 7. SDO STREAM TAG IS INDICATED IN SYNC.....	11
FIGURE 8. STRIPED STREAM ON MULTIPLE SDOS.....	12
FIGURE 9. SDI INBOUND STREAM.....	13
FIGURE 10. SDI STREAM TAG AND DATA .....	13
FIGURE 11. CODEC TRANSMITS DATA OVER MULTIPLE SDIS .....	14
FIGURE 12. LINK RESET TIMING.....	18
FIGURE 13. CODEC INITIALIZATION SEQUENCE.....	19
FIGURE 14. LINK RESET AND INITIALIZATION TIMING .....	64
FIGURE 15. LINK SIGNAL TIMING.....	65
FIGURE 16. OUTPUT TIMING.....	66
FIGURE 17. FILTER CONNECTION .....	68
FIGURE 18. ONBOARD FRONT PANEL HEADER CONNECTION AND FRONT PANEL I/O .....	69
FIGURE 19. ANALOG INPUT/OUTPUT CONNECTION .....	70
FIGURE 20. OPTIONAL S/PDIF OUTPUT .....	70

---



## 1. General Description

The ALC662 series are 5.1 Channel High Definition Audio Codecs designed for Windows Vista premium desktop and mobile PCs. Both the ALC662 and ALC662-VC (ALC662 version C) meet audio performance and function requirements for the latest Microsoft WLP3.10 (Windows Logo Program). The ALC662-VC is an upgraded version of the ALC662 that passes stricter WLP performance requirements that will be effective from 01 June 2008. (See section 2.3 Upgraded Features for Future WLP (ALC662-VC), page 3).

The ALC662 series feature three stereo DACs, two stereo ADCs, and legacy analog input to analog output mixing, to provide fully integrated audio solutions for multimedia PCs and ultra mobile devices.

All analog IO (except CD-IN and PCBEEP) are input and output capable, and three headphone amplifiers are also integrated to drive earphones on front (port-E and port-F) and rear panel (port-D).

The ALC662 series support 16/20/24-bit S/PDIF output function and a sampling rate of up to 96kHz. They offer easy connection of PCs to high quality consumer electronic products such as digital decoders and speakers.

The ALC662 series support host audio from the Intel chipsets, and also from any other HDA compatible audio controller. With EAX/Direct Sound 3D/I3DL2/A3D compatibility, software utilities like Karaoke mode, environment emulation, multi-band of software equalizer, HRTF 3D positional audio, and optional Dolby® Digital Live, DTS® CONNECT™, and Dolby® Home Theater programs. The ALC662 series provide an excellent home entertainment package and game experience for PC users.

## 2. Features

### 2.1. *Hardware Features*

- Meets premium audio requirements for Microsoft WLP 3.10 (ALC662 and ALC662-VC)
- Meets stricter performance requirements for future WLP effective from 01 June 2008 (ALC662-VC)
- Six-channel DAC supports 16/20/24-bit PCM format for 5.1 channel audio solution
- Two stereo ADCs support 16/20-bit PCM format
- All DACs support independent 44.1k/48k/96kHz sample rate
- All ADCs support independent 44.1k/48k/96kHz sample rate
- Supports 44.1k/48k/96kHz S/PDIF output
- All analog jack ports are stereo input and output re-tasking
- Analog differential CD input
- Supports analog PCBEEP input
- Integrates digital BEEP generator
- Up to four channels of microphone array input are supported for AEC/BF application
- Supports legacy analog input to analog output mixer
- Three built-in headphone amplifiers for port-D (rear panel), port-E and port-F (front panel)
- Software selectable 2.5V and 3.2V reference output for microphone bias
- Software selectable boost gain (+10/+20/+30dB) for analog microphone input
- Two jack detection pins: each supports detection of up to 4 jacks
- Jack detection function is supported when device is in power down mode (D3)
- Supports two GPIO pins (General Purpose Input Output)
- Supports EAPD (External Amplifier Power Down) control for external amplifier
- Supports 1.5V~3.3V scalable I/O for HD Audio link
- Supports anti-pop mode when analog power AVDD is on and digital power is off
- 48-pin LQFP ‘Green’ package
- The ALC662-VC is fully pin compatible with the ALC662, and both are pin-to-pin compatible with the ALC88x series and ALC262 series audio codecs

## **2.2. Software Features**

- Meets Microsoft WLP 3.10 and future WLP audio requirements
- WaveRT based audio function driver and logo ready for Windows Vista
- EAX™ 1.0 & 2.0 compatible
- Direct Sound 3D™ compatible
- A3D™ compatible
- I3DL2 compatible
- HRTF 3D Positional Audio (Windows XP only)
- Emulation of 26 sound environments to enhance gaming experience
- Multi-band software equalizer and software tools are provided
- Voice Cancellation and Key Shifting effects
- Dynamic range control (expander, compressor, and limiter) with adjustable parameters
- Intuitive Configuration Panel (Realtek Audio Manager) for enhanced audio experience
- Provides 10-foot GUI for Windows Media Center
- Microphone Acoustic Echo Cancellation (AEC), Noise Suppression (NS), and Beam Forming (BF) technology for voice application
- Smart multiple streaming operation
- Dolby® PCEE program™ (optional software feature)
- DTS® CONNECT™ (optional software feature)
- SRS® TrueSurround HD (optional software feature)

## **2.3. Upgraded Features for Future WLP (ALC662-VC)**

- DAC and ADC keep good THD+N when tested with -1dB test signal (-3dB in WLP3.10)
- DAC and ADC have less than  $\pm 0.02$ dB frequency response ripple ( $< \pm 0.25$ dB in WLP3.10)
- Meets performance measurement when sweeping 44.1kHz sample rate content across 20Hz to 20KHz (20Hz to 17.6KHz in WLP3.10)

## **3. System Applications**

- Desktop and mobile multimedia PCs
- Ultra mobile PCs

## 4. Block Diagram

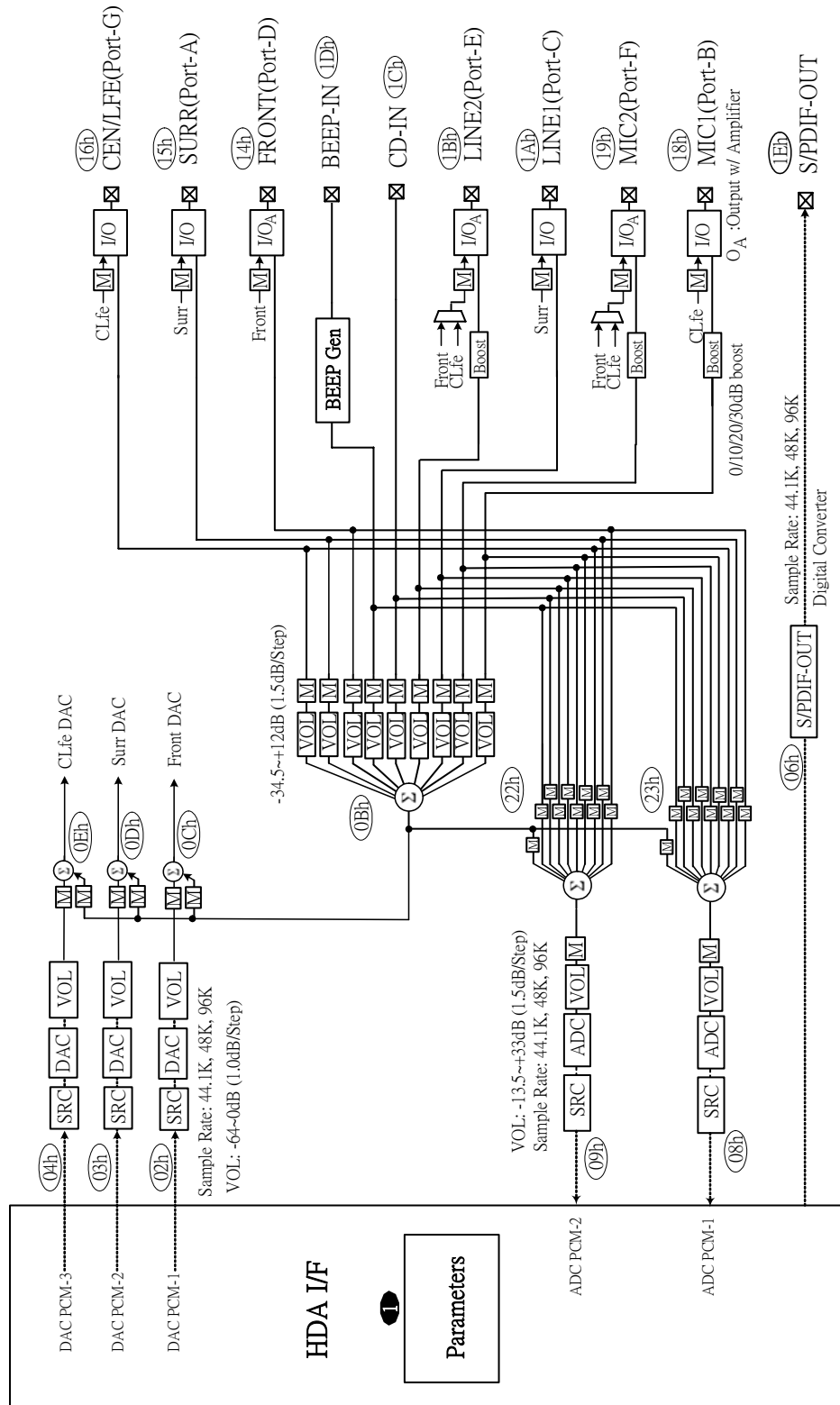

Figure 1. Block Diagram

## 5. Pin Assignments

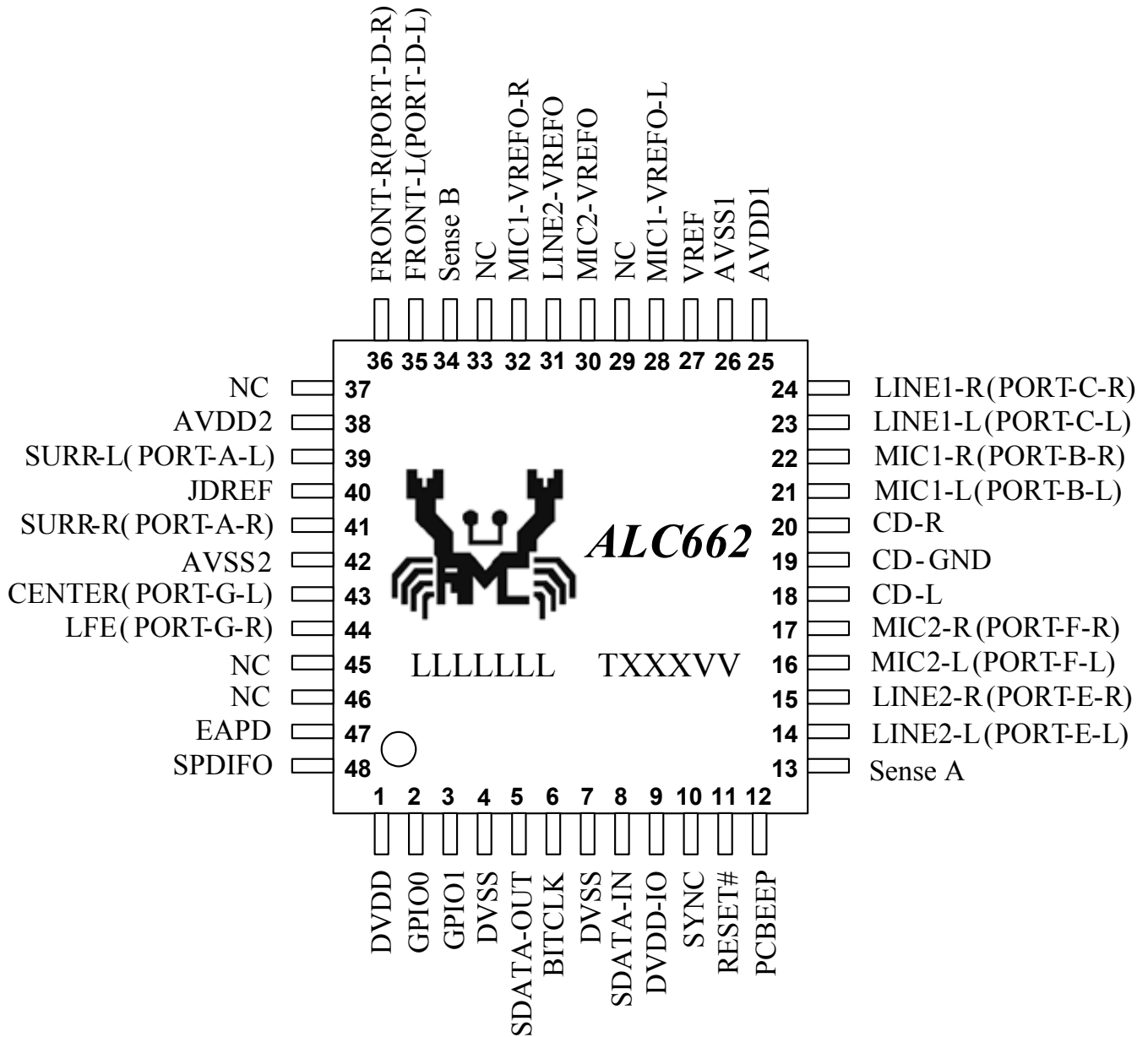

Figure 2. Pin Assignments

### 5.1. Package and Version Identification

Green package is indicated by a 'G' in the location marked 'T' in Figure 2. The version number is shown in the location marked 'VV'. For example, 'VV=C0' indicates silicon version 'C' and stepping version '0', which is the first stepping of the ALC662-VC.

## 6. Pin Descriptions

### 6.1. Digital I/O Pins

**Table 1. Digital I/O Pins**

Name	Type	Pin	Description	Characteristic Definition
RESET#	I	11	H/W Reset	$V_i=0.5*DVDDIO$
SYNC	I	10	Sample Sync (48kHz)	$V_i=0.5*DVDDIO$
BITCLK	I	6	24MHz Bit Clock Input	$V_i=0.5*DVDDIO$
SDATA-OUT	I	5	Serial TDM Data Input	$V_i=0.5*DVDDIO$
SDATA-IN	O	8	Serial TDM Data Output	In: $V_i=0.5*DVDDIO$ ; Out: $V_{OH}=DVDDIO, V_{OL}=DVSS$
SPDIFO	O	48	S/PDIF Output	TTL output has 12mA@75Ω driving capability
EAPD	O	47	External Amplifier Power Down	$V_{OH}=DVDDIO, V_{OL}=DVSS$
GPIO0	IO	2	General Purpose Input/Output 0	In: $V_i=0.5*DVDD$ ; Out: $V_{OH}=DVDD, V_{OL}=DVSS$
GPIO1	IO	3	General Purpose Input/Output 1	In: $V_i=0.5*DVDD$ ; Out: $V_{OH}=DVDD, V_{OL}=DVSS$
				Total: 9 Pins

### 6.2. Analog I/O Pins

**Table 2. Analog I/O Pins**

Name	Type	Pin	Description	Characteristic Definition
LINE2-L	IO	14	2 <sup>nd</sup> Line Input Left Channel	Analog input/output. Default is input (JACK-E-L)
LINE2-R	IO	15	2 <sup>nd</sup> Line Input Right Channel	Analog input/output. Default is input (JACK-E-R)
MIC2-L	IO	16	2 <sup>nd</sup> Stereo Microphone Input Left Channel	Analog input/output. Default is input (JACK-F-L)
MIC2-R	IO	17	2 <sup>nd</sup> Stereo Microphone Input Right Channel	Analog input/output. Default is input (JACK-F-R)
CD-L	I	18	CD Input Left Channel	Analog input. 1.6Vrms of full scale input
CD-GND	I	19	CD Input Reference Ground	Analog input. 1.6Vrms of full scale input
CD-R	I	20	CD Input Right Channel	Analog input. 1.6Vrms of full scale input
MIC1-L	IO	21	1 <sup>st</sup> Stereo Microphone Input Left Channel	Analog input/output. Default is input (JACK-B-L)
MIC1-R	IO	22	1 <sup>st</sup> Stereo Microphone Input Right Channel	Analog input/output. Default is input (JACK-B-R)
LINE1-L	IO	23	1 <sup>st</sup> Line Input Left Channel	Analog input/output. Default is input (JACK-C-L)
LINE1-R	IO	24	1 <sup>st</sup> Line Input Right Channel	Analog input/output. Default is input (JACK-C-R)
PCBEEP	I	12	External PCBEEP Input	Analog input. 1.6Vrms of full scale input
FRONT-L	IO	35	Front Output Left Channel	Analog output (JACK-D-L)
FRONT-R	IO	36	Front Output Right Channel	Analog output (JACK-D-R)
SURR-L	IO	39	Surround Out Left Channel	Analog output (JACK-A-L)
SURR-R	IO	41	Surround Out Right Channel	Analog output (JACK-A-R)
CENTER	O	43	Center Output	Analog output (JACK-G-L)
LFE	O	44	Low Frequency Output	Analog output (JACK-G-R)

Name	Type	Pin	Description	Characteristic Definition
Sense A	I	13	Jack Detect Pin 1	Jack resistor network input 1
Sense B	I	34	Jack Detect Pin 2	Jack resistor network input 2
				Total: 20 Pins

### 6.3. Filter/Reference

**Table 3. Filter/Reference**

Name	Type	Pin	Description	Characteristic Definition
VREF	-	27	Reference Voltage	Typical 2.25V, 10 $\mu$ f capacitor to analog ground
MIC1-VREFO-L	O	28	Bias Voltage for MIC1 Jack	2.5V/3.2V reference voltage
MIC2-VREFO	O	30	Bias Voltage for MIC2 Jack	2.5V/3.2V reference voltage
LINE2-VREFO	O	31	Bias Voltage for LINE2 Jack	2.5V/3.2V reference voltage
MIC1-VREFO-R	O	32	Bias Voltage for MIC1 Jack	2.5V/3.2V reference voltage
JDREF	-	40	Reference Resistor for Jack Detection	20K, 1% external resistor to analog ground
				Total: 6 Pins

### 6.4. Power/Ground

**Table 4. Power/Ground**

Name	Type	Pin	Description	Characteristic Definition
AVDD1	I	25	Analog VDD	Analog power for mixer and amplifier
AVSS1	I	26	Analog GND	Analog ground for mixer and amplifier
AVDD2	I	38	Analog VDD	Analog power for DACs and ADCs
AVSS2	I	42	Analog GND	Analog ground for DACs and ADCs
DVDD	I	1	Digital VDD	Digital power for core
DVSS	I	4	Digital GND	Digital ground for core
DVDD-IO	I	9	Digital VDD	Digital power for HDA link (1.5V~3.3V)
DVSS	I	7	Digital GND	Digital ground for HDA link
				Total: 8 Pins

### 6.5. NC (Not Connected) Pins

**Table 5. Not Connected Pins**

Symbol	Type	Pin	Description
NC	-	29, 33, 37, 45, 46	Not Connected.
			Total: 5 Pins

## 7. High Definition Audio Link Protocol

### 7.1. Link Signals

The High Definition Audio (HDA) Link is the digital serial interface that connects the HDA codecs to the HDA Controller. The HDA link protocol is controller synchronous, based on a 24.0MHz BIT-CLK sent by the HDA controller. The input and output streams, including command and PCM data, are isochronous with a 48kHz frame rate. Figure 3 shows the basic concept of the HDA link protocol.

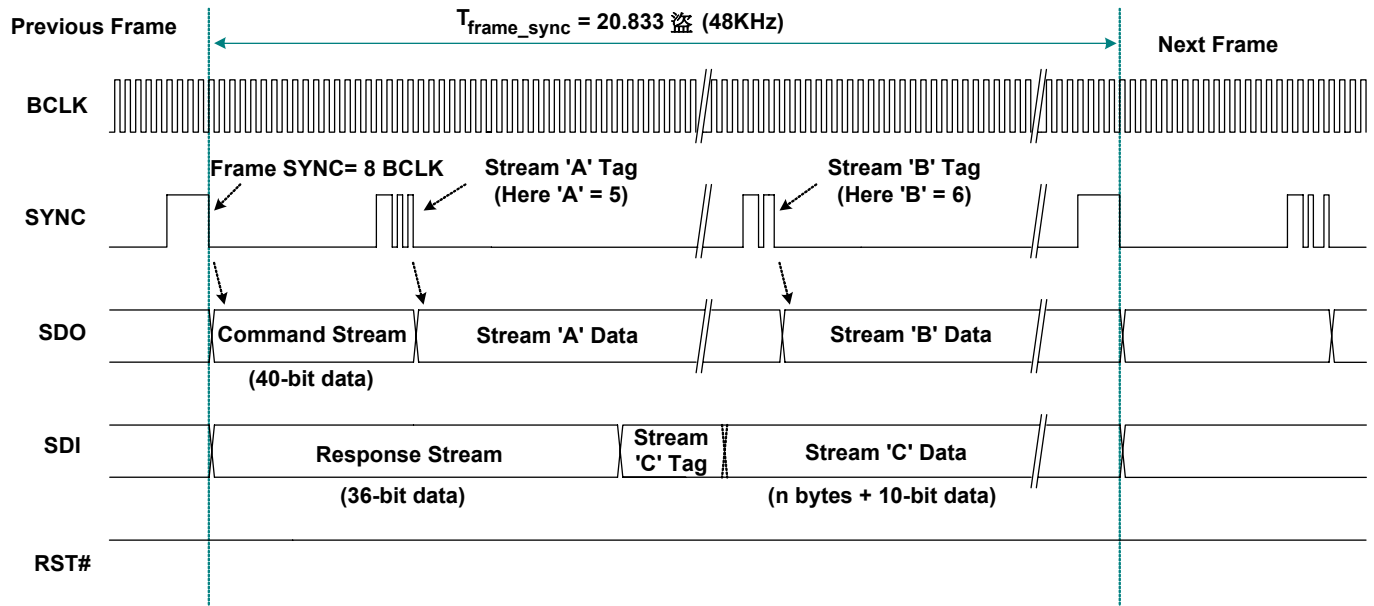

Figure 3. HDA Link Protocol



### 7.1.1. Signal Definitions

**Table 6. Link RESET#**

Item	Description
BCLK	24.0MHz bit clock sourced from the HDA controller and connecting to all codecs.
SYNC	A 48kHz signal used to synchronize input and output streams on the link. It is sourced from the HDA controller and connects to all codecs.
SDO	Serial Data Output signal driven by the HDA controller to all codecs. Commands and data streams are carried on SDO. The data rate is double-pumped; the controller drives data onto the SDO, the codec samples data present on SDO with respect to each edge of BCLK. The HDA controller must support at least one SDO. To extend outbound bandwidth, multiple SDOs may be supported.
SDI	Serial Data Input signal driven by the codec. This is point-to-point serial data from the codec to the HDA controller. The controller must support at least one SDI. Up to a maximum of 15 SDI's can be supported. SDI is driven by the codec at each rising edge of BCLK, and sampled by the controller at each rising edge of BCLK. SDI can be driven by the controller to initialize the codec's ID.
RESET#	Active low reset signal. Asserted to reset the codec to default power-on state. RESET# is sourced from the HDA controller and connects to all codecs.

**Table 7. HDA Signal Definitions**

Signal Name	Source	Type for Controller	Description
BCLK	Controller	Output	Global 24.0MHz Bit Clock.
SYNC	Controller	Output	Global 48kHz Frame Sync and Outbound Tag Signal.
SDO	Controller	Output	Serial Data Output from Controller.
SDI	Codec/Controller	Input/Output	Serial data input from codec. Weakly pulled down by the controller.
RESET#	Controller	Output	Global Active Low Reset Signal.

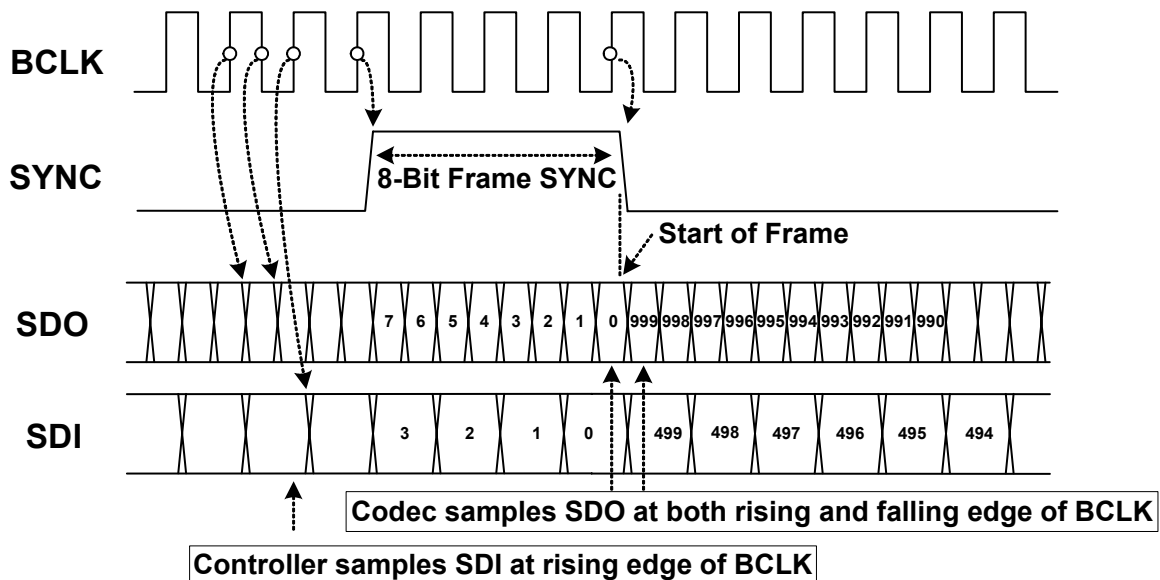
**Figure 4. Bit Timing**

### 7.1.2. Signaling Topology

The HDA controller supports two SDOs for the outbound stream, up to 15 SDIs for the inbound stream. RESET#, BCLK, SYNC, SDO0, and SDO1 are driven by the controller to codecs. Each codec drives its own point-to-point SDI signal(s) to the controller.

Figure 5, on page 10, shows the possible connections between the HDA controller and codecs:

- Codec 0 is a basic connection. There is one single SDO and one single SDI for normal transmission
- Codec 1 has two SDOs for doubled outbound rate, and a single SDI for normal inbound rate
- Codec 3 supports a single SDO for normal outbound rate, and two SDIs for doubled inbound rate
- Codec N has two SDOs and multiple SDIs

The multiple SDOs and multiple SDIs are used to expand the transmission rate between controller and codecs. Section 7.2 Frame Composition, page 11, describes the detailed outbound and inbound stream compositions for single and multiple SDOs/SDIs.

The connections shown in Figure 5 can be implemented concurrently in an HDA system. The ALC662 is designed to receive a single SDO stream.

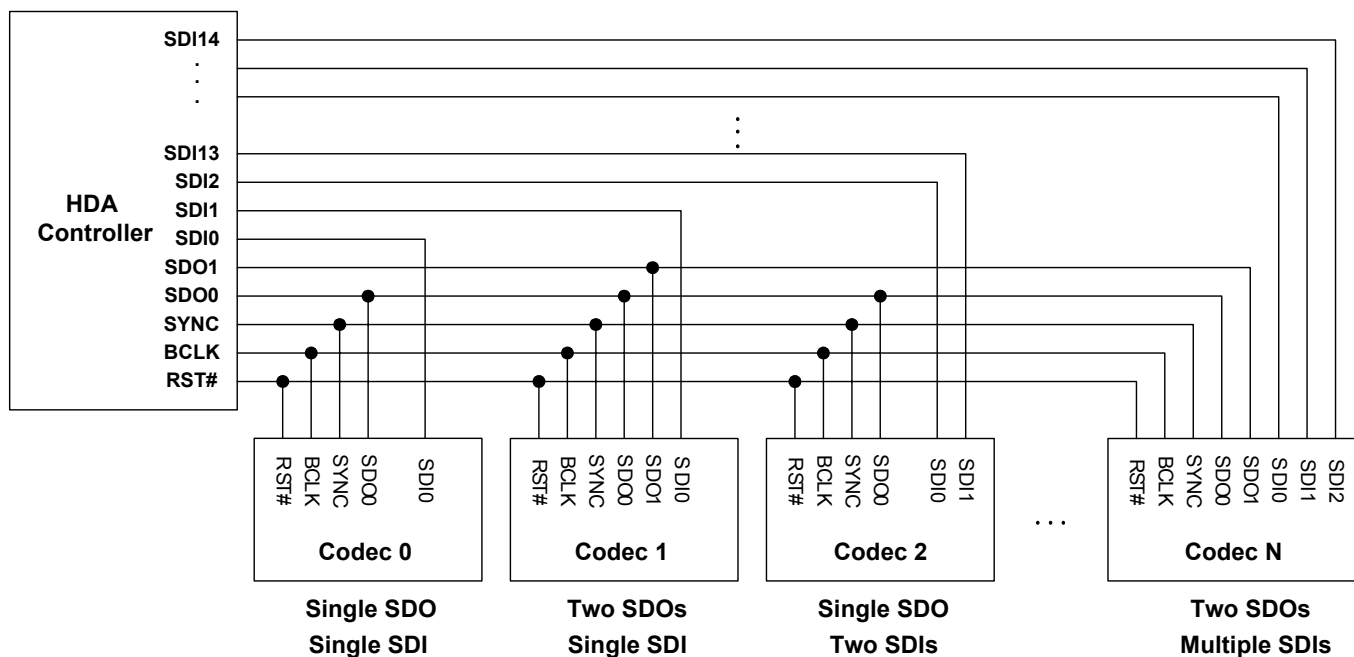

**Figure 5. Signaling Topology**

## 7.2. Frame Composition

### 7.2.1. Outbound Frame – Single SDO

An outbound frame is composed of one 32-bit command stream and multiple data streams. There are one or multiple sample blocks in a data stream. Only one sample block exists in a stream if the HDA controller delivers a 48kHz rate of samples to the codec. Multiple sample blocks in a stream means the sample rate is a multiple of 48kHz. This means there should be 2 blocks in the same stream to carry 96kHz samples (Figure 6).

For outbound frames, the stream tag is not in SDO, but in the SYNC signal. A new data stream is started at the end of the stream tag. The stream tag includes a 4-bit preamble and 4-bit stream ID (Figure 7).

To keep the cadence of converters bound to the same stream, samples for these converters must be placed in the same block.

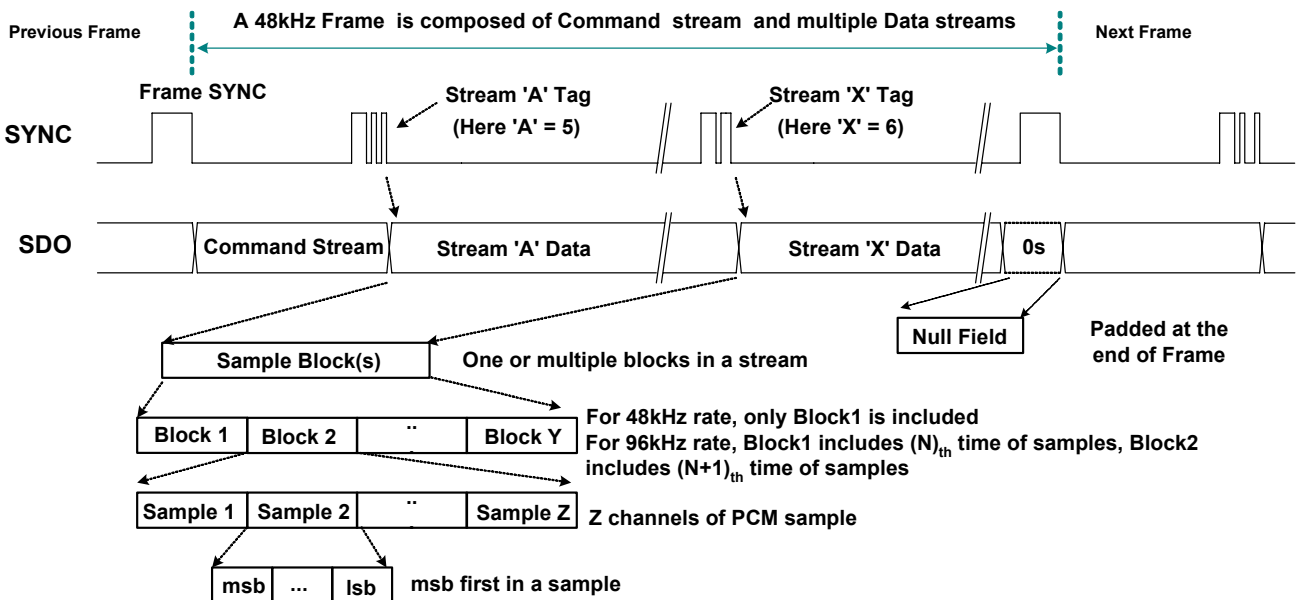

Figure 6. SDO Outbound Frame

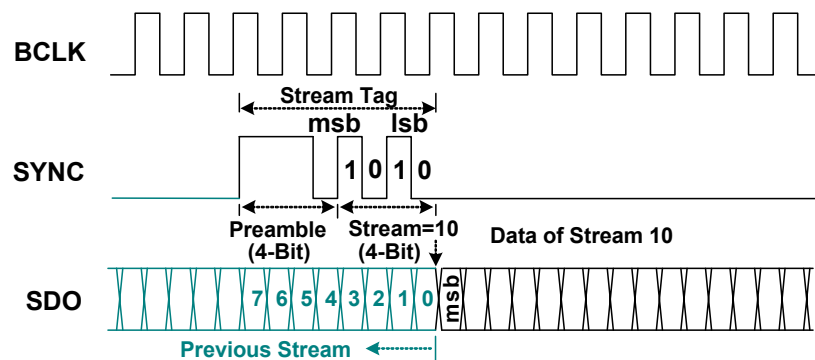

Figure 7. SDO Stream Tag is Indicated in SYNC

### 7.2.2. Outbound Frame – Multiple SDOs

The HDA controller allows two SDO signals to be used to stripe outbound data, completing transmission in less time to get more bandwidth. If software determines that the target codec supports multiple SDO capability, it enables the ‘Stripe Control’ bit in the controller’s Output Stream Control Register to initiate a specific stream (Stream ‘A’ in Figure 8) to be transmitted on multiple SDOs. In this case, the MSB of stream data is always carried on SDO0, the second bit on SDO1 and so forth.

SDO1 is for transmitting a striped stream. The codec does not support multiple SDOs connected to SDO0.

To ensure that all codecs can determine their corresponding stream, the command stream is not striped. It is always transmitted on SDO0, and copied on SDO1.

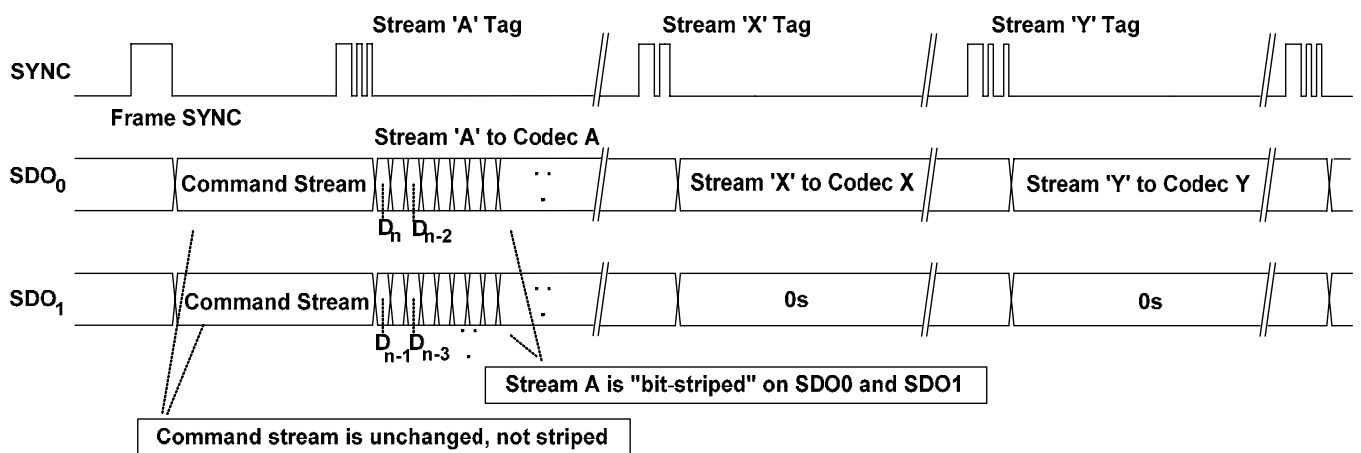

**Figure 8. Striped Stream on Multiple SDOs**

### 7.2.3. Inbound Frame – Single SDI

An Inbound Frame – Single SDI is composed of one 36-bit response stream and multiple data streams. Except for the initialization sequence (turnaround and address frame), SDI is driven by the codec at each rising edge of BCLK. The controller also samples data at the rising edge of BCLK (Figure 9).

The SDI stream tag is not carried by SYNC, but included in the SDI. A complete SDI data stream includes one 4-bit stream tag, one 6-bit data length, and n-bit sample blocks. Zeros will be padded if the total length of the contiguous sample blocks within a given stream is not of integral byte length (Figure 10).

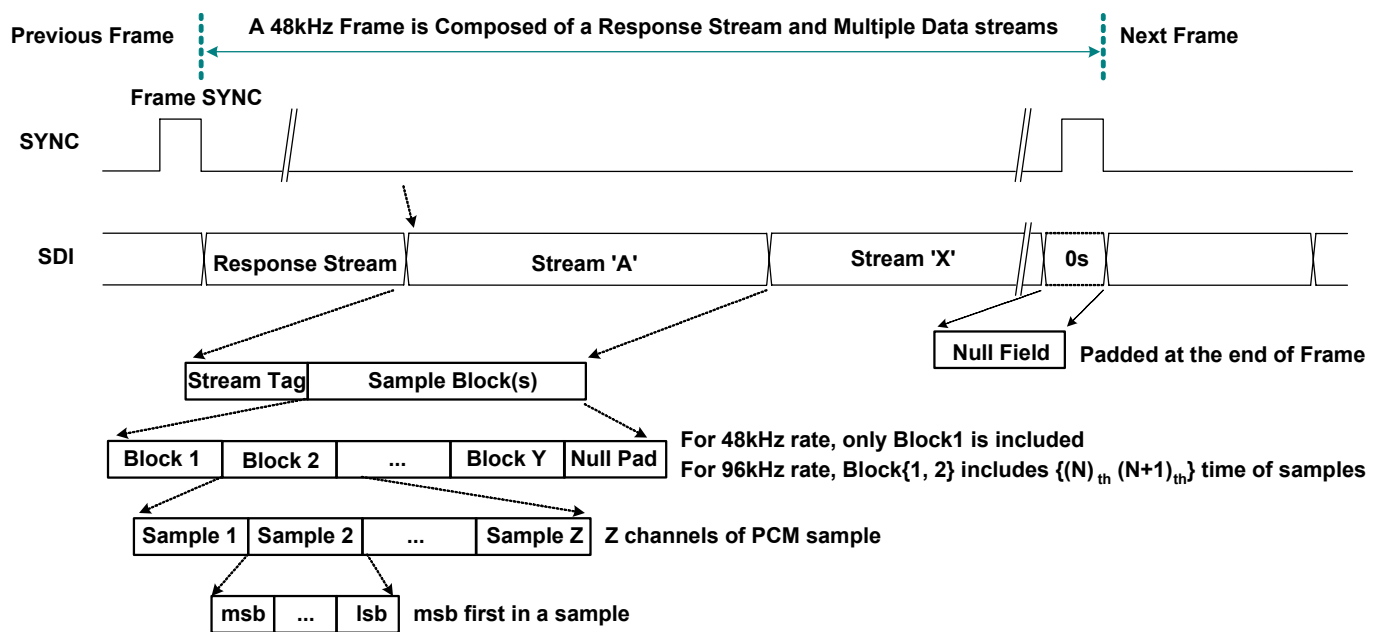

Figure 9. SDI Inbound Stream

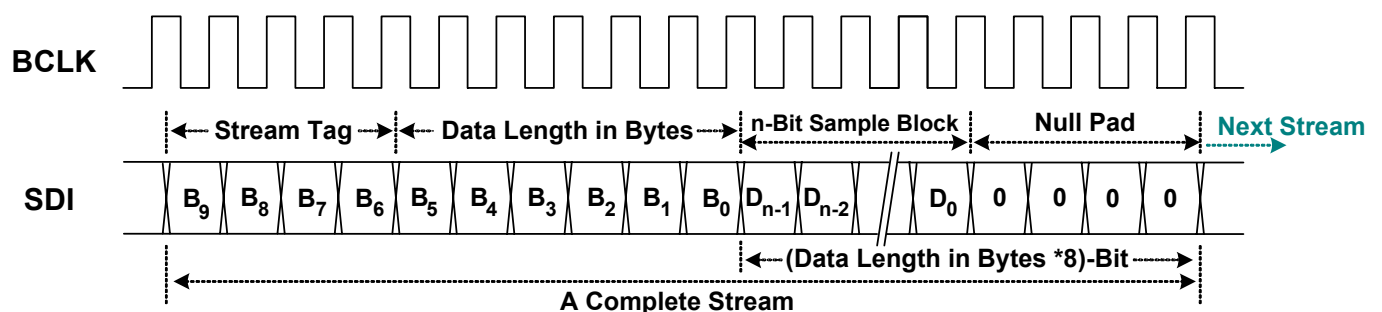
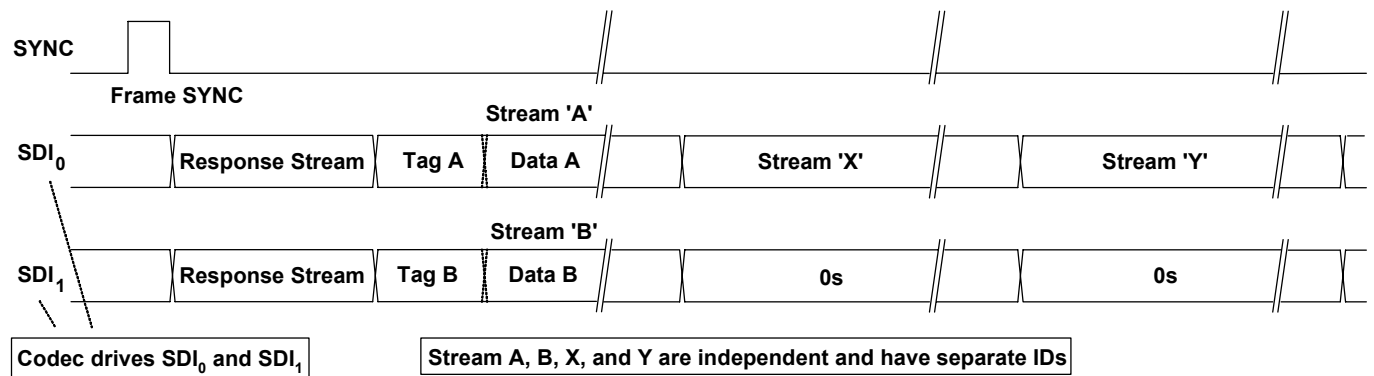

Figure 10. SDI Stream Tag and Data

### 7.2.4. Inbound Frame – Multiple SDIs

A codec can deliver data to the controller on multiple SDIs to achieve higher bandwidth. If an inbound stream exceeds the data transfer limits of a single SDI, the codec can divide the data onto separate SDI signals, each of which operate independently, with different stream numbers at the same frame time. This is similar to having multiple codecs connected to the controller. The controller samples the divided stream into separate memory with multiple DMA descriptors, then software re-combines the divided data into a meaningful stream.



**Figure 11. Codec Transmits Data Over Multiple SDIs**

### 7.2.5. Variable Sample Rates

The HDA link is designed for sample rates of 48kHz. Variable sample rates are delivered in multiple or sub-multiple rates of 48kHz. Two sample blocks per frame result in a 96kHz delivery rate, one sample block over two frames results in a 24kHz delivery rate. The HDA specification states that the sample rate of the outbound stream be synchronized by the controller, not by the codec. Each stream has its own sample rate, independent of any other stream.

The HDA controller supports 48kHz and 44.1kHz base rates. Table 8, page 15, shows the recommended sample rates based on multiples or sub-multiples of one of the two base rates.

Rates in sub-multiples ( $1/n$ ) of 48kHz are interleaving  $n$  frames containing no sample blocks. Rates in multiples ( $n$ ) of 48kHz contain  $n$  sample blocks in a frame. Table 9, page 15, shows the delivery cadence of variable rates based on 48kHz.

The HDA link is defined to operate at a fixed 48kHz frame rate. To deliver samples in (sub) multiple rates of 44.1kHz, an appropriate ratio between 44.1kHz and 48kHz must be maintained to avoid frequency drift. The appropriate ratio between 44.1kHz and 48kHz is 147/160. Meaning 147 sample blocks are transmitted every 160 frames.

The cadence ‘12-11-11-12-11-11-12-11-11-12-11-11-11- (repeat)’ interleaves 13 frames containing no sample blocks in every 160 frames. It provides a low long-term frequency drift for 44.1kHz of delivery rate. Rates in sub-multiples ( $1/n$ ) of 44.1kHz also follow this cadence *and* interleave  $n$  empty frames.

Rates in multiples (n) of 44.1kHz applying this cadence contain n sample blocks in the non-empty frame AND interleave an empty frame between non-empty frames Table 10, page 16).

**Table 8. Defined Sample Rate and Transmission Rate**

(Sub) Multiple	48kHz Base	44.1kHz Base
1/6	8kHz (1 sample block every 6 frames)	-
1/4	12kHz (1 sample block every 4 frames)	11.025kHz (1 sample block every 4 frames)
1/3	16kHz (1 sample block every 3 frames)	-
1/2	-	22.05kHz (1 sample block every 2 frames)
2/3	32kHz (2 sample blocks every 3 frames)	-
1	48kHz (1 sample block per frame)	44.1kHz (1 sample block per frame)
2	96kHz (2 sample blocks per frame)	88.2kHz (2 sample blocks per frame)
4	192kHz (4 sample blocks per frame)	176.4kHz (4 sample blocks per frame)

**Table 9. 48kHz Variable Rate of Delivery Timing**

Rate	Delivery Cadence	Description
8kHz	YNNNNN (repeat)	One sample block is transmitted in every 6 frames
12kHz	YNNN (repeat)	One sample block is transmitted in every 4 frames
16kHz	YNN (repeat)	One sample block is transmitted in every 3 frames
32kHz	Y <sup>2</sup> NN (repeat)	One sample block is transmitted in every 6 frames
48kHz	Y (repeat)	One sample block is transmitted in every 6 frames
96kHz	Y <sup>2</sup> (repeat)	Two sample blocks are transmitted in each frame
192kHz	Y <sup>4</sup> (repeat)	Four sample blocks are transmitted in each frame

*N: No sample block in a frame*

*Y: One sample block in a frame*

*Yx: X sample blocks in a frame*

**Table 10. 44.1kHz Variable Rate of Delivery Timing**

Rate	Delivery Cadence
11.025kHz	{12}{-}{11}{-}{11}{-}{12}{-}{11}{-}{11}{-}{12}{-}{11}{-}{11}{-}{12}{-}{11}{-}{11}{-}{12}{-}{11}{-}{11}{-}{12}{-}{11}{-}{11}{-}
22.05kHz	{12}{-}{11}{-}{11}{-}{12}{-}{11}{-}{11}{-}{12}{-}{11}{-}{11}{-}{12}{-}{11}{-}{11}{-}{12}{-}{11}{-}{11}{-}{12}{-}{11}{-}{11}{-}
44.1kHz	12-11-11-12-11-11-12-11-11-12-11-11-11- (repeat)
88.2kHz	12 <sup>2</sup> -11 <sup>2</sup> -11 <sup>2</sup> -12 <sup>2</sup> -11 <sup>2</sup> -11 <sup>2</sup> -12 <sup>2</sup> -11 <sup>2</sup> -11 <sup>2</sup> -12 <sup>2</sup> -11 <sup>2</sup> -11 <sup>2</sup> - (repeat)
174.4kHz	12 <sup>4</sup> -11 <sup>4</sup> -11 <sup>4</sup> -12 <sup>4</sup> -11 <sup>4</sup> -11 <sup>4</sup> -12 <sup>4</sup> -11 <sup>4</sup> -11 <sup>4</sup> -12 <sup>4</sup> -11 <sup>4</sup> -11 <sup>4</sup> - (repeat)

- 11.025kHz: {12}=YNNNYNN  
 {11}=YNNNYNN  
 {-}=NNNN
- 22.050kHz: {12}=YN  
 {11}=YN  
 {-}=NN
- 44.1kHz      12- =Contiguous 12 frames containing 1 sample blocks each, followed by one frame with no sample block.
- 88.2kHz      12<sup>2</sup>- =Contiguous 12 frames containing 2 sample blocks each, followed by one frame with no sample block.
- 174.4kHz     12<sup>4</sup>- =Contiguous 12 frames containing 4 sample blocks each, followed by one frame with no sample block.



### **7.3. Reset and Initialization**

There are two types of reset within an HDA link:

- **Link Reset.**  
Generated by assertion of the RESET# signal. All codecs return to their power-on state
- **Codec Reset.**  
Generated by software directing a command to reset a specific codec back to its default state

An initialization sequence is requested after any of the following three events:

- Link Reset
- Codec Reset
- Codec changes its power state, e.g., hot docking a codec to an HDA system

#### **7.3.1. Link Reset**

A link reset may be caused by any of the following three events:

1. The HDA controller asserts RESET# for any reason (power up, or PCI reset)
2. Software initiates a link reset via the ‘CRST’ bit in the Global Control Register (GCR) of the HDA controller
3. Software initiates power management sequences. Figure 12, page 18, shows the ‘Link Reset’ timing including the ‘Enter’ sequence (❶~❷) and ‘Exit’ sequence (❸~❹)

Enter ‘Link Reset’:

- ❶ Software writes a 0 to the ‘CRST’ bit in the Global Control Register of the HDA controller to initiate a link reset
- ❷ As the controller completes the current frame, it does not signal the normal 8-bit frame SYNC at the end of the frame
- ❸ The controller drives SYNC and all SDOs to low. Codecs also drive SDIs to low
- ❹ The controller asserts the RESET# signal to low, and enters the ‘Link Reset’ state
- ❺ All link signals driven by controller and codecs should be tri-state by internal pull-low resistors

Exit from ‘Link Reset’:

- ⑥ If BCLK is re-started for any reason (codec, wake-up event, power management, etc.)
- ⑦ Software is responsible for de-asserting RESET# after a minimum of 100µs BCLK running time (the 100µsec provides time for the codec PLL to stabilize)
- ⑧ Minimum of 4 BCLKs after RESET# is de-asserted, the controller starts to signal normal frame SYNC
- ⑨ The codec drives its SDI to request an initialization sequence (when the SDI is driven high at the last bit of frame SYNC)

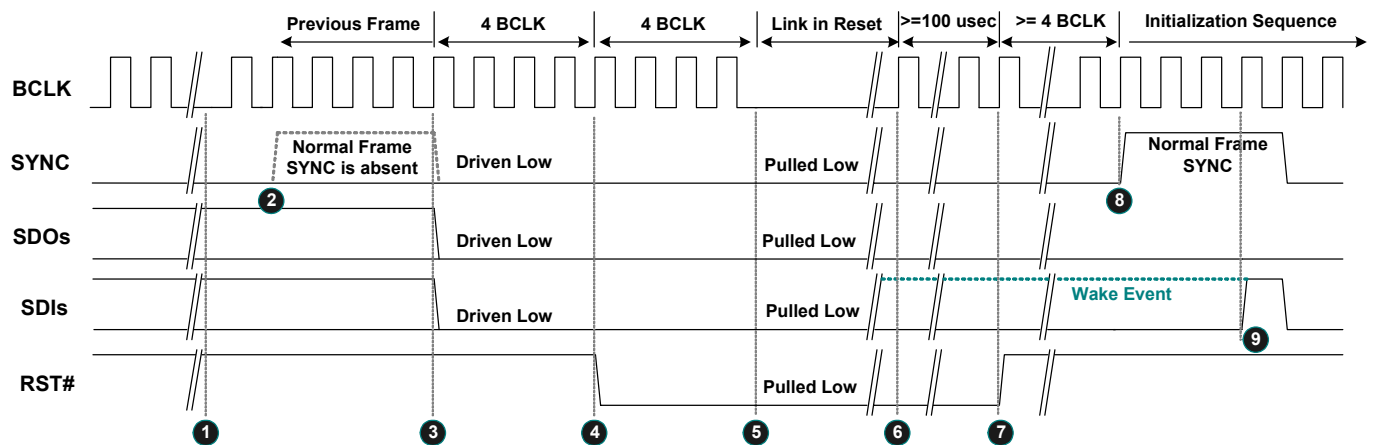

Figure 12. Link Reset Timing

### 7.3.2. Codec Reset

A ‘Codec Reset’ is initiated via the Codec RESET command verb. It results in the target codec being reset to the default state. After the target codec completes its reset operation, an initialization sequence is requested.

### 7.3.3. Codec Initialization Sequence

- ❶ The codec drives SDI high at the last bit of SYNC to request a Codec Address (CAD) from the controller
- ❷ The codec stops driving the SDI during this turnaround period
- ❸❹❺❻ The controller drives SDI to assign a CAD to the codec
- ❼ The controller releases the SDI after the CAD has been assigned
- ❽ Normal operating state

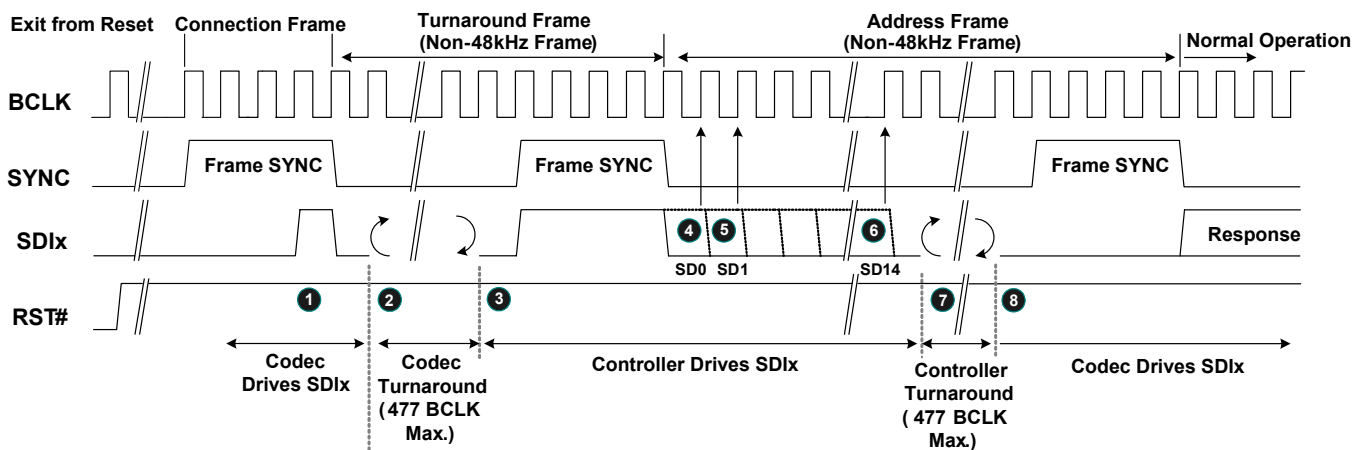

Figure 13. Codec Initialization Sequence

## 7.4. Verb and Response Format

### 7.4.1. Command Verb Format

There are two types of verbs: one with 4-bit identifiers (4-bit verbs) and 16-bits of data, the other with 12-bit identifiers (12-bit verbs) and 8-bits of data. Table 11 shows the 4-bit verb structure of a command stream sent from the controller to operate the codec. Table 12 is the 12-bit verb structure that gets and controls parameters in the codec.

Table 11. 40-Bit Commands in 4-Bit Verb Format

Bit [39:32]	Bit [31:28]	Bit [27:20]	Bit [19:16]	Bit [15:0]
Reserved	Codec Address	Node ID	Verb ID	Payload

Table 12. 40-Bit Commands in 12-Bit Verb Format

Bit [39:32]	Bit [31:28]	Bit [27:20]	Bit [19:8]	Bit [7:0]
Reserved	Codec Address	Node ID	Verb ID	Payload

**Table 13. Supported Commands**

Supported Verb	Get Verb	Set Verb	Root Node	Audio Function Group	Modem Function Group <sup>*1</sup>	HDMI Function Group <sup>*1</sup>	Vendor Define Group <sup>*1</sup>	Audio Out Converter	Audio In Converter	Pin Widget	Sum Widget	Selector Widget	Power Widget <sup>*1</sup>	Volume Knob	Beep Generator	Vendor Define Widget
Get parameter	F00	-	Y	Y	-	-	-	Y	Y	Y	Y	Y	Y	Y	Y	Y
Connection Select	F01	701	-	-	-	-	-	-	Y	Y	-	Y	-	-	-	-
Get Connection List Entry	F02	-	-	-	-	-	-	-	Y	Y	Y	Y	-	-	-	-
Processing State	F03	703	-	-	-	-	-	-	-	-	-	-	-	-	-	-
Coefficient Index	D--	5--	-	-	-	-	-	-	-	-	-	-	-	-	-	Y
Processing Coefficient	C--	4--	-	-	-	-	-	-	-	-	-	-	-	-	-	Y
Amplifier Gain/Mute	B--	3--	-	-	-	-	-	-	Y	Y	Y	-	-	-	-	-
Stream Format	A--	2--	-	-	-	-	-	Y	Y	-	-	-	-	-	-	-
Digital Converter 1	F0D	70D	-	-	-	-	-	Y	Y	-	-	-	-	-	-	-
Digital Converter 2	F0D	70E	-	-	-	-	-	Y	Y	-	-	-	-	-	-	-
Power State	F05	705	-	Y	-	-	-	-	-	-	-	-	-	-	-	-
Channel / Stream ID	F06	706	-	-	-	-	-	Y	Y	-	-	-	-	-	-	-
SDI Select	F04	704	-	-	-	-	-	-	-	-	-	-	-	-	-	-
Pin Widget Control	F07	707	-	-	-	-	-	-	-	Y	-	-	-	-	-	-
Unsolicited Enable	F08	708	-	-	-	-	-	-	-	Y	-	-	-	Y	-	-
Pin Sense	F09	709	-	-	-	-	-	-	-	Y	-	-	-	-	-	-
EAPD / BTL Enable	F0C	70C	-	-	-	-	-	-	-	-	-	-	-	-	-	-
All GPIO Control	F10- F1A	710- 71A	-	-	-	-	-	-	-	-	-	-	-	-	-	-
Beep Generator Control	F0A	70A	-	-	-	-	-	-	-	-	-	-	-	-	Y	-
Volume Knob Control	F0F	70F	-	-	-	-	-	-	-	-	-	-	-	-	-	-
Subsystem ID, Byte 0	F20	720	-	Y	-	-	-	-	-	-	-	-	-	-	-	-
Subsystem ID, Byte 1	F20	721	-	Y	-	-	-	-	-	-	-	-	-	-	-	-
Subsystem ID, Byte 2	F20	722	-	Y	-	-	-	-	-	-	-	-	-	-	-	-
Subsystem ID, Byte 3	F20	723	-	Y	-	-	-	-	-	-	-	-	-	-	-	-
Config Default, Byte 0	F1C	71C	-	-	-	-	-	-	-	Y	-	-	-	-	-	-
Config Default, Byte 1	F1C	71D	-	-	-	-	-	-	-	Y	-	-	-	-	-	-
Config Default, Byte 2	F1C	71E	-	-	-	-	-	-	-	Y	-	-	-	-	-	-
Config Default, Byte 3	F1C	71F	-	-	-	-	-	-	-	Y	-	-	-	-	-	-
RESET	-	7FF	-	Y	-	-	-	-	-	-	-	-	-	-	-	-

<sup>\*1</sup>: The ALC662 does not support Modem/HDMI/Vendor groups and Power State widgets.

**Table 14. Supported Parameters**

Supported Parameter	Parameter ID	Root Node	Audio Function Group	Modem Function Group <sup>*1</sup>	HDMI Function Group <sup>*1</sup>	Vendor Define Group <sup>*1</sup>	Audio Out Converter	Audio In Converter	Pin Widget	Sum Widget	Selector Widget	Power Widget <sup>*1</sup>	Volume Knob	Beep Generator	Vendor Define Widget
Vendor ID	00	Y	-	-	-	-	-	-	-	-	-	-	-	-	-
Revision ID	02	Y	-	-	-	-	-	-	-	-	-	-	-	-	-
Subordinate Node Count	04	Y	Y	-	-	-	-	-	-	-	-	-	-	-	-
Function Group Type	05	-	Y	-	-	-	-	-	-	-	-	-	-	-	-
Audio Function Group Capabilities	08	-	Y	-	-	-	-	-	-	-	-	-	-	-	-
Audio Widget Capabilities	09	-	-	-	-	-	Y	Y	Y	Y	Y	Y	Y	Y	Y
Sample Size, Rate	0A	-	Y	-	-	-	Y	Y	-	-	-	-	-	-	-
Stream Formats	0B	-	Y	-	-	-	Y	Y	-	-	-	-	-	-	-
Pin Capabilities	0C	-	-	-	-	-	-	-	Y	-	-	-	-	-	-
Input Amp Capabilities	0D	-	-	-	-	-	-	Y	-	Y	Y	-	-	-	-
Output Amp Capabilities	12	-	-	-	-	-	-	-	Y	Y	-	-	-	-	-
Connection List Length	0E	-	-	-	-	-	-	Y	Y	Y	Y	-	-	-	-
Supported Power States	0F	-	Y	-	-	-	Y	Y	Y	Y	Y	-	-	-	Y
Processing Capabilities	10	-	-	-	-	-	-	-	-	-	-	-	-	-	Y
GPI/O Count	11	-	-	-	-	-	-	-	-	-	-	-	-	-	-
Volume Knob Capabilities	13	-	-	-	-	-	-	-	-	-	-	-	-	-	-

<sup>\*1</sup>: The ALC662 does not support Modem/HDMI/Vendor groups and Power State widgets.

## 7.4.2. Response Format

There are two types of response from the codec to the controller. Solicited Responses are returned by the codec in response to a current command verb. The codec will send Solicited Response data in the next frame, without regard to the Set (Write) or Get (Read) command. The 32-bit response is interpreted by software, opaque to the controller.

Unsolicited Responses are sent by the codec independently of software requests. Jack Detection or GPI status information can be actively delivered to the controller and interpreted by software. The ‘Tag’ in Bit[31:28] is used to identify unsolicited events. This tag is undefined in the HDA specifications.

**Table 15. Solicited Response Format**

Bit [35]	Bit [34]	Bit [33:32]	Bit [31:0]
Valid	Unsol=0	Reserved	Response

**Table 16. Unsolicited Response Format**

Bit [35]	Bit [34]	Bit [33:32]	Bit [31:28]	Bit [27:0]
Valid	Unsol=1	Reserved	Tag	Response

## 7.5. Power Management

The ALC662 does not support Wake-Up events when in low-power mode. All power management state changes in widgets are driven by software. Table 17 shows the System Power State Definitions. Table 18 indicates those nodes that support power management. To simplify power control, software can configure whole codec power states through the audio function (NID=01h). Output converters (DACs) and input converters (ADCs) have no individual power control to supply fine-grained power control.

### 7.5.1. System Power State Definitions

**Table 17. System Power State Definitions**

Power States	Definitions
D0	All power on. Individual DACs and ADCs can be powered up or down as required.
D1	All amplifiers and converters (DACs and ADCs) are powered down. State maintained, analog reference stays up.
D2	All amplifiers and converters (DACs and ADCs) are powered down. State maintained, but analog reference is off (D1 + analog reference off).
D3 (Hot)	Power still supplied. The codec stops the internal clock. State is maintained.
D3 (Cold)	All power removed. State lost.

## 7.5.2. Power Controls in NID 01h

**Table 18. Power Controls in NID 01h**

Item	Description	D0	D1	D2	D3	Link Reset
Audio Function (NID=01h)	LINK Response	Normal	Normal	Normal	PD	PD
	Front DAC (Node 02h)	Normal	PD	PD	PD	PD
	Surr DAC (Node 03h)	Normal	PD	PD	PD	PD
	Cen/LFE DAC (Node 04h)	Normal	PD	PD	PD	PD
	ADC (Node 08h)	Normal	PD	PD	PD	PD
	ADC (Node 09h)	Normal	PD	PD	PD	PD
	All Headphone Drivers	Normal	Normal	PD	PD	Normal
	All Mixers	Normal	Normal	PD	PD	Normal
All Reference	Normal	Normal	PD	PD	Normal	

Note: PD=Powered Down.

## 7.5.3. Powered Down Conditions

**Table 19. Powered Down Conditions**

Condition	Description
LINK Response powered down	Internal clock is stopped. S/DATA-IN and S/PDIF-OUT are floated with pulled low 47K resistors internally. S/PDIF-IN is also floated. Detection of 'Link Reset Entry' and 'Link Reset Exit' sequences are supported. All states are maintained if DVDD is supplied
Front DAC powered down	Analog block and digital filter are powered down
Surr DAC powered down	Analog block and digital filter are powered down
CEN/LFE DAC powered down	Analog block and digital filter are powered down
ADC 08h powered down	Analog block and digital filter are powered down. Data on S/DATA-IN is quiet
ADC 09h powered down	Analog block and digital filter are powered down. Data on S/DATA-IN is quiet
Headphone Driver powered down	All headphone drivers are powered down
Mixers powered down	All internal mixer widgets are powered down. The DC reference and VREFOUTx at individual pin complexes are still alive
Reference power down	All internal references, DC reference, and VREFOUTx at individual pin complexes are off

## 8. Supported Verbs and Parameters

This section describes the Verbs and Parameters supported by various widgets in the ALC662. If a verb is not supported by the addressed widget, it will respond with 32 bits of '0'.

### 8.1. Verb – Get Parameters (Verb ID=F00h)

The 'Get Parameters' verb is used to get system information and the function capabilities of the HDA codec. All the parameters are read-only. There are a total of 15 ID parameters defined for each widget. Some parameters are supported only in a specific widget. Refer to section 7.4.1 Command Verb Format, page 19, to get detailed information about supported parameters.

**Table 20. Verb – Get Parameters (Verb ID=F00h)**

Get Parameter Command Format				Codec Response Format
Bit [31:28]	Bit [27:20]	Bit [19:8]	Payload Bit [7:0]	Response [31:0]
CAd=X	Node ID=00h	Verb ID=F00h	Parameter ID[7:0]	32-bit Response

*Note: If the parameter ID is not supported, the returned response is 32 bits of '0'.*

#### 8.1.1. Parameter – Vendor ID (Verb ID=F00h, Parameter ID=00h)

**Table 21. Parameter – Vendor ID (Verb ID=F00h, Parameter ID=00h)**

Codec Response Format	
Bit	Description
31:16	Vendor ID=10ECh (Realtek's PCI vendor ID).
15:0	Device ID=0662h.

*Note: The Root Node (NID=00h) supports this parameter.*

#### 8.1.2. Parameter – Revision ID (Verb ID=F00h, Parameter ID=02h)

**Table 22. Parameter – Revision ID (Verb ID=F00h, Parameter ID=02h)**

Codec Response Format	
Bit	Description
31:24	Reserved. Read as 0's.
23:20	MajRev=1h. The major version number (in decimal) of the HDA Specification.
19:16	MinRev=0h. The minor version number (in decimal) of the HDA Specification.
15:8	Revision ID. The vendor's revision number. <i>Note: 01h indicates ALC662 silicon.</i>
7:0	Stepping ID. The vendor's stepping number within the given Revision ID.

*Note: The Root Node (NID=00h) supports this parameter.*



### 8.1.3. Parameter – Subordinate Node Count (Verb ID=F00h, Parameter ID=04h)

For the root node, the Subordinate Node Count provides information about audio function group nodes associated with the root node.

For function group nodes, it provides the total number of widgets associated with this function node.

**Table 23. Parameter – Subordinate Node Count (Verb ID=F00h, Parameter ID=04h)**

Codec Response Format

Bit	Description
31:24	Reserved. Read as 0's.
23:16	Starting Node Number. The starting node number in the sequential widgets.
15:8	Reserved. Read as 0's.
7:0	Total Number of Nodes. For a root node, this is the total number of function groups in the root node. For a function group, this is the total number of widget nodes in the function group.

### 8.1.4. Parameter – Function Group Type (Verb ID=F00h, Parameter ID=05h)

**Table 24. Parameter – Function Group Type (Verb ID=F00h, Parameter ID=05h)**

Codec Response Format

Bit	Description
31:9	Reserved. Read as 0's.
8	UnSol Capable. 0: Unsolicited response is not supported by this function group 1: Unsolicited response is supported by this function group
7:0	Function Group Type. 00h: Reserved                      01h: Audio Function                      02h: Modem Function 03h~7Fh: Reserved                80h~FFh: Vendor Defined Function

### 8.1.5. Parameter – Audio Function Capabilities (Verb ID=F00h, Parameter ID=08h)

**Table 25. Parameter – Audio Function Capabilities (Verb ID=F00h, Parameter ID=08h)**

Codec Response Format

Bit	Description
31:17	Reserved. Read as 0's.
16	Beep Generator. A '1' indicates the presence of an integrated Beep generator within the Audio Function Group.
15:12	Reserved. Read as 0's.
11:8	Input Delay. Number of samples delay from analog input to HDA link.
7:4	Reserved. Read as 0's.
3:0	Output Delay. Number of samples delay from HDA link to analog output.

### 8.1.6. Parameter – Audio Widget Capabilities (Verb ID=F00h, Parameter ID=09h)

**Table 26. Parameter – Audio Widget Capabilities (Verb ID=F00h, Parameter ID=09h)**

Codec Response Format

Bit	Description
31:24	Reserved. Read as 0's.
23:20	Widget Type. 0h: Audio Output                      1h: Audio Input                      2h: Mixer 3h: Selector                              4h: Pin Complex                      5h: Power Widget 6h: Volume Knob Widget              7h~Eh: Reserved                      Fh: Vendor defined audio widget
19:16	Delay. Samples delayed between the HDA link and widgets.
15:12	Reserved. Read as 0's.
11:	L-R Swap. 0: Left channel and right channel swapping is not supported 1: Left channel and right channel swapping is supported
10	Power Control. 0: Power control is not supported on this widget 1: Power control is supported on this widget
9	Digital. 0: An analog input or output converter 1: A widget translating digital data between the HDA link and digital I/O (S/PDIF, I2S, etc.)
8	ConnList. Connection List. 0: Connected to HDA link. No Connection List Entry will be queried 1: Connection List Entry must be queried
7	UnsolCap. Unsolicited Capable. 0: Unsolicited response is not supported 1: Unsolicited response is supported
6	ProcWidget. Processing Widget. 0: No processing control 1: Processing control is supported
5	Reserved. Read as 0.
4	Format Override. <i>Note: The ALC662 supports 16/20/24-bit with 44.1kHz, 48kHz, and 96kHz sample rate. The format (parameter ID=0Ah) must be queried</i>
3	AmpParOvr (AMP Param Override). Override amplifier parameters (Gain Control) in individual output Pin Complexes, ADCs, and Mixer widgets.
2	OutAmpPre (Out AMP Present).
1	InAmpPre (In AMP Present). There are amplifiers (Gain Control) in individual ADCs and Mixer widgets.
0	Stereo. 0: Mono Widget 1: Stereo Widget

### 8.1.7. Parameter – Supported PCM Size, Rates (Verb ID=F00h, Parameter ID=0Ah)

Parameters in audio functions provide default information about formats. Individual converters have their own parameters to provide supported formats if their ‘Format Override’ bit is set.

**Table 27. Parameter – Supported PCM Size, Rates (Verb ID=F00h, Parameter ID=0Ah)**

Codec Response Format

Bit	Description
31:21	Reserved. Read as 0's.
20	B32. 32-bit audio format support. 0: Not supported                      1: Supported
19	B24. 24-bit audio format support. 0: Not supported                      1: Supported (The ALC662 DAC supports this format)
18	B20. 20-bit audio format support. 0: Not supported                      1: Supported (The ALC662 DAC supports this format)
17	B16. 16-bit audio format support. 0: Not supported                      1: Supported (The ALC662 DAC supports this format)
16	B8. 8-bit audio format support. 0: Not supported                      1: Supported
15:12	Reserved. Read as 0's.
11	R12. 384kHz (=8*48kHz) rate support. 0: Not supported                      1: Supported
10	R11. 192kHz (=4*48kHz) rate support. 0: Not supported                      1: Supported
9	R10. 176.4Hz (=4*44.1kHz) rate support. 0: Not supported                      1: Supported
8	R9. 96kHz (=2*48kHz) rate support. 0: Not supported                      1: Supported (The ALC662 DAC and ADC support this sample rate)
7	R8. 88.2kHz (=2*44.1kHz) rate support. 0: Not supported                      1: Supported
6	R7. 48kHz rate support. 0: Not supported                      1: Supported (The ALC662 DAC and ADC support this sample rate)
5	R6. 44.1kHz rate support. 0: Not supported                      1: Supported (The ALC662 DAC and ADC support this sample rate)
4	R5. 32kHz (=2/3*48kHz) rate support. 0: Not supported                      1: Supported
3	R4. 22.05kHz (=1/2*44.1kHz) rate support. 0: Not supported                      1: Supported
2	R3. 16kHz (=1/3*48kHz) rate support. 0: Not supported                      1: Supported
1	R2. 11.025kHz (=1/4*44.1kHz) rate support. 0: Not supported                      1: Supported
0	R1. 8kHz (=1/6*48kHz) rate support. 0: Not supported                      1: Supported

### 8.1.8. Parameter – Supported Stream Formats (Verb ID=F00h, Parameter ID=0Bh)

Parameters in this node only provide default information for audio function groups. Individual converters have their own parameters to provide supported formats if the ‘Format Override’ bit is set.

**Table 28. Parameter – Supported Stream Formats (Verb ID=F00h, Parameter ID=0Bh)**

Codec Response Format

Bit	Description
31:3	Reserved. Read as 0's.
2	AC3. 0: Not supported                      1: Supported
1	Float32. 0: Not supported                      1: Supported
0	PCM. 0: Not supported                      1: Supported (The ALC662 DAC and ADC support this format)

*Note: Input converters and output converters support this parameter.*

### 8.1.9. Parameter – Pin Capabilities (Verb ID=F00h, Parameter ID=0Ch)

The Pin Capabilities parameter returns a bit field describing the capabilities of the Pin Complex widget.

**Table 29. Parameter – Pin Capabilities (Verb ID=F00h, Parameter ID=0Ch)**

Codec Response Format

Bit	Description														
31:16	Reserved. Read as 0's.														
15:8	VREF Control Capability. ‘1’ in corresponding bit field indicates signal levels of associated Vrefout are specified as a percentage of AVDD. <table border="1" style="margin-left: 40px;"> <thead> <tr> <th>7:6</th> <th>5</th> <th>4</th> <th>3</th> <th>2</th> <th>1</th> <th>0</th> </tr> </thead> <tbody> <tr> <td>Reserved</td> <td>100%</td> <td>80%</td> <td>Reserved</td> <td>Ground</td> <td>50%</td> <td>Hi-Z</td> </tr> </tbody> </table>	7:6	5	4	3	2	1	0	Reserved	100%	80%	Reserved	Ground	50%	Hi-Z
7:6	5	4	3	2	1	0									
Reserved	100%	80%	Reserved	Ground	50%	Hi-Z									
7	Reserved.														
6	Balanced I/O Pin. ‘1’ indicates this pin complex has balanced pins.														
5	Input Capable. ‘1’ indicates this pin complex supports input.														
4	Output Capable. ‘1’ indicates this pin complex supports output.														
3	Headphone Drive Capable. ‘1’ indicates this pin complex has an amplifier to drive a headphone.														
2	Presence Detect Capable. ‘1’ indicates this pin complex can detect whether there is a device plugged in.														
1	Trigger Required. ‘1’ indicates whether a software trigger is required for an impedance measurement.														
0	Impedance Sense Capable. ‘1’ indicates this pin complex can perform analog sense on the attached device to determine its type.														

*Note: Only Pin Complex widgets support this parameter.*

### 8.1.10. Parameter – Amplifier Capabilities (Verb ID=F00h, Input Amplifier Parameter ID=0Dh)

Parameters in this node provide audio function group default information. Individual converters have their own parameters to provide amplifier capabilities if the ‘AMP Param Override’ bit is set.

**Table 30. Parameter – Amplifier Capabilities (Verb ID=F00h, Input Amplifier Parameter ID=0Dh)**

Codec Response Format

Bit	Description
31	(Input) Mute Capable.
30:23	Reserved. Read as 0.
22:16	Step Size. Indicates the size of each step in the gain range.
15	Reserved. Read as 0.
14:8	Number of Steps. Indicates the number of steps in the gain range. ‘0’ means the gain is fixed.
7	Reserved. Read as 0.
6:0	Offset. Indicates which step is 0dB.

### 8.1.11. Parameter – Amplifier Capabilities (Verb ID=F00h, Output Amplifier Parameter ID=12h)

Parameters in this node provide audio function group default information. Individual converters have their own parameters to provide amplifier capabilities if the ‘AMP Param Override’ bit is set.

**Table 31. Parameter – Amplifier Capabilities (Verb ID=F00h, Output Amplifier Parameter ID=12h)**

Codec Response Format

Bit	Description
31	(Output) Mute Capable.
30:23	Reserved. Read as 0.
22:16	Step Size. Indicates the size of each step in the gain range. Each individual step may be 0~32dB, specified in 0.25dB steps. ‘0’ indicates 0.25dB steps. ‘127’ indicates 32dB steps.
15	Reserved. Read as 0.
14:8	Number of Steps. Indicates the number of steps in the gain range. ‘0’ means the gain is fixed.
7	Reserved. Read as 0.
6:0	Offset. Indicates which step is 0dB.

### 8.1.12. Parameter – Connect List Length (Verb ID=F00h, Parameter ID=0Eh)

Parameters in this node provide audio function widget connection information.

**Table 32. Parameter – Connect List Length (Verb ID=F00h, Parameter ID=0Eh)**

Codec Response Format

Bit	Description
31:8	Reserved. Read as 0.
7	Short Form. 0: Short Form                      1: Long Form
6:0	Connect List Length. Indicates the number of inputs connected to a widget. If the Connect List Length is 1, there is only one input, and there is no Connection Select Control (not a MUX widget).

### 8.1.13. Parameter – Supported Power States (Verb ID=F00h, Parameter ID=0Fh)

**Table 33. Parameter – Supported Power States (Verb ID=F00h, Parameter ID=0Fh)**

Codec Response Format

Bit	Description
31:4	Reserved. Read as 0's.
3	D3Sup. 1: Power state D3 is supported
2	D2Sup. 1: Power state D2 is supported
1	D1Sup. 1: Power state D1 is supported
0	D0Sup. 1: Power state D0 is supported

### 8.1.14. Parameter – Processing Capabilities (Verb ID=F00h, Parameter ID=10h)

**Table 34. Parameter – Processing Capabilities (Verb ID=F00h, Parameter ID=10h)**

Codec Response Format

Bit	Description
31:16	Reserved. Read as 0's.
15:8	NumCoeff. Number of Coefficient.
7:1	Reserved. Read as 0's.
0	Benign. 0: Processing unit is not linear and time invariant 1: Processing unit is linear and time invariant

### 8.1.15. Parameter – GPIO Capabilities (Verb ID=F00h, Parameter ID=11h)

**Table 35. Parameter – GPIO Capabilities (Verb ID=F00h, Parameter ID=11h)**

Codec Response Format

Bit	Description
31	GPIWake=0. The ALC662 does not support GPIO wake-up function.
30	GPIUnsol=1. The ALC662 supports GPIO unsolicited response.
29:24	Reserved. Read as 0's.
23:16	NumGPIs=00h. No GPI pin is supported.
15:8	NumGPOs=00h. No GPO pin is supported.
7:0	NumGPIOs=02h. Two GPIO pins are supported.

### 8.1.16. Parameter – Volume Knob Capabilities (Verb ID=F00h, Parameter ID=13h)

**Table 36. Parameter – Volume Knob Capabilities (Verb ID=F00h, Parameter ID=13h)**

Codec Response Format for NID=21h (Volume Control Knob)

Bit	Description
31:8	Reserved. Read as 0's.
7	Delta. 0: Software cannot modify the Volume Control Knob volume 1: Software can write a base volume to the Volume Control Knob
6:0	NumSteps. The number of steps in the range of the Volume Control Knob

*Note: The ALC662 does not support volume knob and will respond with 0s to this parameter.*

## 8.2. Verb – Get Connection Select Control (Verb ID=F01h)

**Table 37. Verb – Get Connection Select Control (Verb ID=F01h)**

Get Command Format

Bit [31:28]	Bit [27:20]	Bit [19:8]	Payload Bit [7:0]
CAd=X	Node ID=Xh	Verb ID=F01h	0's

Codec Response Format

Response [31:0]
Bit[7:0] are Connection Index

Codec Response for NID = 19h (MIC2, PORT-F)

Bit	Description
31:8	0's.
7:0	Connection Index Currently Set (Default value is 00h). 00h: Sum Widget NID=0Ch 01h: Sum Widget NID=0Eh Other: Reserved

Codec Response for NID = 1Bh (LINE2, PORT-E)

Bit	Description
31:8	0's
7:0	Connection Index Currently Set (Default value is 00h). 00h: Sum Widget NID=0Ch 01h: Sum Widget NID=0Eh Other: Reserved

Codec Response for other NID

Bit	Description
31:0	Not Supported (returns 00000000h).

## 8.3. Verb – Set Connection Select (Verb ID=701h)

**Table 38. Verb – Set Connection Select (Verb ID=701h)**

Set Command Format

Bit [31:28]	Bit [27:20]	Bit [19:8]	Payload Bit [7:0]
CAd=X	Node ID=Xh	Verb ID=701h	Select Index [7:0]

Codec Response Format

Response [31:0]
0's for all nodes



## 8.4. Verb – Get Connection List Entry (Verb ID=F02h)

**Table 39. Verb – Get Connection List Entry (Verb ID=F02h)**

Get Command Format

Bit [31:28]	Bit [27:20]	Bit [19:8]	Payload Bit [7:0]
CAd=X	Node ID=Xh	Verb ID=F02h	Offset Index - N[7:0]

Codec Response Format

Response [31:0]
32-bit Response

Codec Response for NID=08h (ADC)

Bit	Description
31:8	Connection List Entry (N+3), (N+2), (N+1). Returns 000000h.
7:0	Connection List Entry (N). Returns 23h (Sum Widget) for N=0~3. Returns 00h for N>3.

Codec Response for NID=09h (ADC)

Bit	Description
31:8	Connection List Entry (N+3), (N+2), (N+1). Returns 000000h.
7:0	Connection List Entry (N). Returns 22h (Sum Widget) for N=0~3. Returns 00h for N>3.

Codec Response for NID=0Bh (Mixer)

Bit	Description
31:24	Connection List Entry (N+3). Returns 1Bh (Pin Complex – LINE2) for N=0~3. Returns 15h (Pin Complex – SURR) for N=4~7. Returns 00h for N>7.
23:16	Connection List Entry (N+2). Returns 1Ah (Pin Complex – LINE1) for N=0~3. Returns 14h (Pin Complex – FRONT) for N=4~7. Returns 00h for N>7.
15:8	Connection List Entry (N+1). Returns 19h (Pin Complex – MIC2) for N=0~3. Returns 1Dh (Pin Complex – PCBEEP) for N=4~7. Returns 00h for N>7.
7:0	Connection List Entry (N). Returns 18h (Pin Complex – MIC1) for N=0~3. Returns 1Ch (Pin Complex – CD) for N=4~7. Returns 16h (Pin Complex – CEN/LFE) for N=8~11. Returns 00h for N>11.

Codec Response for NID=0Ch (Front Sum)

Bit	Description
31:24	Connection List Entry (N). Returns 00h
23:16	Connection List Entry (N+2). Returns 00h.

**Codec Response for NID=0Ch (Front Sum)**

Bit	Description
15:8	Connection List Entry (N+1). Returns 0Bh (Mixer) for N=0~3. Returns 00h for N>3.
7:0	Connection List Entry (N). Returns 02h (Front DAC) for N=0~3. Returns 00h for N>3.

**Codec Response for NID=0Dh (Surround Sum)**

Bit	Description
31:24	Connection List Entry (N). Returns 00h.
23:16	Connection List Entry (N+2). Returns 00h.
15:8	Connection List Entry (N+1). Returns 0Bh (Mixer) for N=0~3. Returns 00h for N>3.
7:0	Connection List Entry (N). Returns 03h (Surround DAC) for N=0~3. Returns 00h for N>3.

**Codec Response for NID=0Eh (Cen/Lfe Sum)**

Bit	Description
31:24	Connection List Entry (N). Returns 00h.
23:16	Connection List Entry (N+2). Returns 00h.
15:8	Connection List Entry (N+1). Returns 0Bh (Mixer) for N=0~3. Returns 00h for N>3.
7:0	Connection List Entry (N). Returns 04h (Cen/Lfe DAC) for N=0~3. Returns 00h for N>3.

**Codec Response for NID=14h (FRONT, Port-D)**

Bit	Description
31:8	Connection List Entry (N+3), (N+2), (N+1). Returns 000000h for n>3.
7:0	Connection List Entry (N). Returns 0Ch (Sum Widget NID=0Ch) for N=0~3. Returns 00h for N>3.

**Codec Response for NID=15h (SURR, Port-D)**

Bit	Description
31:8	Connection List Entry (N+3), (N+2), (N+1). Returns 000000h for n>3.
7:0	Connection List Entry (N). Returns 0Dh (Sum Widget NID=0Dh) for N=0~3. Returns 00h for N>3.

**Codec Response for NID=16h (CEN/LFE, Port-G)**

Bit	Description
31:8	Connection List Entry (N+3), (N+2), (N+1). Returns 000000h for n>3.
7:0	Connection List Entry (N). Returns 0Eh (Sum Widget NID=0Eh) for N=0~3.                      Returns 00h for N>3.

**Codec Response for NID=18h (MIC1, Port-B)**

Bit	Description
31:8	Connection List Entry (N+3), (N+2), (N+1). Returns 000000h for n>3.
7:0	Connection List Entry (N). Returns 0Eh (Sum Widget NID=0Eh) for N=0~3.                      Returns 00h for N>3.

**Codec Response for NID=19h (MIC2, Port-F)**

Bit	Description
31:16	Connection List Entry (N+3), (N+2). Returns 0000h for n>3.
15:8	Connection List Entry (N+1). Returns 0Eh (Sum Widget NID=0Eh) for N=0~3.                      Returns 00h for N>3.
7:0	Connection List Entry (N). Returns 0Ch (Sum Widget NID=0Ch) for N=0~3.                      Returns 00h for N>3.

**Codec Response for NID=1Ah (LINE1, Port-C)**

Bit	Description
31:8	Connection List Entry (N+3), (N+2), (N+1). Returns 000000h for n>3.
7:0	Connection List Entry (N). Returns 0Dh (Sum Widget NID=0Dh) for N=0~3.                      Returns 00h for N>3.

**Codec Response for NID=1Bh (LINE2, Port-E)**

Bit	Description
31:16	Connection List Entry (N+3), (N+2). Returns 0000h for n>3.
15:8	Connection List Entry (N+1). Returns 0Eh (Sum Widget NID=0Eh) for N=0~3.                      Returns 00h for N>3.
7:0	Connection List Entry (N). Returns 0Ch (Sum Widget NID=0Ch) for N=0~3.                      Returns 00h for N>3.

**Codec Response for NID=1Eh (Pin Widget: S/PDIF-OUT)**

Bit	Description
31:8	Connection List Entry (N+3), (N+2), (N+1). Returns 000000h.
7:0	Connection List Entry (N). Returns 06h (S/PDIF-OUT Converter) for N=0~3. Returns 00h for N>3.

**Codec Response for NID=22h/23h (Sum Widget)**

Bit	Description
31:23	Connection List Entry (N+3). Returns 1Bh (Pin Widget LINE2, port-E) for N=0~3. Returns 15h (Pin Widget SURR, port-A) for N=4~7. Returns 00h for n>7.
23:16	Connection List Entry (N+2). Returns 1Ah (Pin Widget LINE1, port-C) for N=0~3. Returns 14h (Pin Widget FRONT, port-D) for N=4~7. Returns 00h for N>7.
15:8	Connection List Entry (N+1). Returns 19h (Pin Widget MIC2, port-F) for N=0~3. Returns 1Dh (Pin Widget PCBEEP) for N=4~7. Returns 0Bh (Mixer) for N=8~11. Returns 00h for N>11.
7:0	Connection List Entry (N). Returns 18h (Pin Widget MIC1, port-B) for N=0~3. Returns 1Ch (Pin Widget CD) for N=4~7. Returns 16h (Pin Widget CEN/LFE, port-G) for N=8~11. Returns 00h for N>11.

**Codec Response for Other NID**

Bit	Description
31:0	Not Supported (returns 00000000h).

## 8.5. Verb – Get Processing State (Verb ID=F03h)

**Table 40. Verb – Get Processing State (Verb ID=F03h)**
**Get Command Format**

Bit [31:28]	Bit [27:20]	Bit [19:8]	Payload Bit [7:0]
CAd=X	Node ID=Xh	Verb ID=F03h	0's

**Codec Response Format**

Response [31:0]
32-bit response

**Codec Response for All NID**

Bit	Description
31:0	Not Supported (returns 00000000h).

## 8.6. Verb – Set Processing State (Verb ID=703h)

**Table 41. Verb – Set Processing State (Verb ID=703h)**

Set Command Format

Bit [31:28]	Bit [27:20]	Bit [19:8]	Payload Bit [7:0]
CAd=X	Node ID=Xh	Verb ID=703h	Processing State [7:0]

Codec Response Format

Response [31:0]
0's for all nodes

Codec Response for all NID

Bit	Description
31:0	0's.

## 8.7. Verb – Get Coefficient Index (Verb ID=Dh)

**Table 42. Verb – Get Coefficient Index (Verb ID=Dh)**

Get Command Format

Bit [31:28]	Bit [27:20]	Bit [19:16]	Payload Bit [15:0]
CAd=X	Node ID=20h	Verb ID=Dh	0's

Codec Response Format

Response [31:0]
Bit [15:0] are Coefficient Index

Codec Response for NID=20h (Realtek Defined Registers)

Bit	Description
31:16	Reserved. Read as 0's.
15:0	Coefficient Index.

Codec Response for Other NID

Bit	Description
31:0	Not Supported (returns 00000000h).

## 8.8. Verb – Set Coefficient Index (Verb ID=5h)

**Table 43. Verb – Set Coefficient Index (Verb ID=5h)**

Set Command Format

Bit [31:28]	Bit [27:20]	Bit [19:16]	Payload Bit [15:0]
CAd=X	Node ID=20h	Verb ID=5h	Coefficient Index [15:0]

Codec Response Format

Response [31:0]
0's for all nodes

Codec Response for All NID

Bit	Description
31:0	0's.

## 8.9. Verb – Get Processing Coefficient (Verb ID=Ch)

**Table 44. Verb – Get Processing Coefficient (Verb ID=Ch)**

Get Command Format

Bit [31:28]	Bit [27:20]	Bit [19:16]	Payload Bit [15:0]
CAd=X	Node ID=20h	Verb ID=Ch	0's

Codec Response Format

Response [31:0]
Processing Coefficient [15:0]

Codec Response for NID=20h (Realtek Defined Registers)

Bit	Description
31:16	Reserved. Read as 0's.
15:0	Processing Coefficient.

Codec Response for Other NID

Bit	Description
31:0	Not Supported (returns 00000000h).

## 8.10. Verb – Set Processing Coefficient (Verb ID=4h)

**Table 45. Verb – Set Processing Coefficient (Verb ID=4h)**

Set Command Format

Bit [31:28]	Bit [27:20]	Bit [19:16]	Payload Bit [15:0]
CAd=X	Node ID=20h	Verb ID=4h	Coefficient [15:0]

Codec Response Format

Response [31:0]
0's for all nodes

Codec Response for All NID

Bit	Description
31:0	0's.

## 8.11. Verb – Get Amplifier Gain (Verb ID=Bh)

This verb is used to get gain/attenuation settings from each widget.

**Table 46. Verb – Get Amplifier Gain (Verb ID=Bh)**

Get Command Format				Codec Response Format	
<b>Bit [31:28]</b>	<b>Bit [27:20]</b>	<b>Bit [19:16]</b>	<b>Payload Bit [15:0]</b>	<b>Response [31:0]</b>	
CAd=X	Node ID=Xh	Verb ID=Bh	‘Get’ payload [15:0]	Bit[7:0] are responsible for ‘Get’	

‘Get’ Payload in Command Bit[15:0]

Bit	Description
15	Get Input/Output. 0: Input amplifier gain is requested 1: Output amplifier gain is requested
14	Reserved. Read as 0.
13	Get Left/Right. 0: Right amplifier gain is requested 1: Left amplifier gain is requested
12:4	Reserved. Read as 0’s.
3:0	Index[3:0] for Input Source. Select amplifier for this converter. If a widget has no multiple input sources, the index will be ignored.

Codec Response for 02h (FRONT DAC), 03h (SURR DAC), 04h (CEN/LFE DAC)

Bit	Description
31:8	0’s.
7	Bit-15 is 0 in ‘Get Amplifier Gain’: Read as 0 (No Input Amplifier Mute). Bit-15 is 1 in ‘Get Amplifier Gain’: Read as 0 (No Output Amplifier Mute).
6:0	Bit-15 is 0 in ‘Get Amplifier Gain’: Read as 0 (No Input Amplifier Gain). Bit-15 is 1 in ‘Get Amplifier Gain’: Output Amplifier Gain [6:0]. 7-bit step value (0~64) specifying the volume from –64B~0dB in 1dB steps.

Codec Response for 08h (ADC)

Bit	Description
31:8	0’s.
7	Bit-15 is 0 in ‘Get Amplifier Gain’: Input Amplifier Mute. 0: Unmute 1: Mute Bit-15 is 1 in ‘Get Amplifier Gain’: Read as 0 (No Output Amplifier Mute).
6:0	Bit-15 is 0 in ‘Get Amplifier Gain’: Input Amplifier Gain [6:0]. 7-bit step value (0~31) specifying the volume from –13.5B~+33dB in 1.5dB steps. Bit-15 is 1 in ‘Get Amplifier Gain’: Read as 0’s (No Output Amplifier Mute).

**Codec Response for 09h (ADC)**

Bit	Description
31:8	0's.
7	Bit-15 is 0 in 'Get Amplifier Gain': Input Amplifier Mute. 0: Unmute 1: Mute Bit-15 is 1 in 'Get Amplifier Gain': Read as 0 (No Output Amplifier Mute).
6:0	Bit-15 is 0 in 'Get Amplifier Gain': Input Amplifier Gain [6:0]. 7-bit step value (0~31) specifying the volume from -13.5B~+33dB in 1.5dB steps. Bit-15 is 1 in 'Get Amplifier Gain': Read as 0's (No Output Amplifier Mute).

**Codec Response for NID=0Bh (MIXER Sum Widget)**

Bit	Description
31:8	0's.
7	Bit-15 is 0 in 'Get Amplifier Gain': Input Amplifier Mute. 0: Unmute 1: Mute (Default for all Index) Bit-15 is 1 in 'Get Amplifier Gain': Read as 0 (No Output Amplifier Mute).
6:0	Bit-15 is 0 in 'Get Amplifier Gain': Input Amplifier Gain [6:0]. 7-bit step value (0~31) specifying the volume from -34.5dB~+12dB in 1.5dB steps. Bit-15 is 1 in 'Get Amplifier Gain': Read as 0's (No Output Amplifier Mute).

**Codec Response for NID=0Ch~0Eh (Sum Widget: Front, Surr, Cen/Lfe)**

Bit	Description
31:8	0's.
7	Bit-15 is 0 in 'Get Amplifier Gain': Input Amplifier Mute. 0: Unmute 1: Mute Bit-15 is 1 in 'Get Amplifier Gain': Read as 0 (No Output Amplifier Mute).
6:0	Bit-15 is 0 in 'Get Amplifier Gain': Read as 0 (No Input Amplifier Gain). Bit-15 is 1 in 'Get Amplifier Gain': Read as 0 (No Output Amplifier Gain).

**Codec Response for NID=14h, 15h, 16h and 1Ah (Pin Widget: FRONT/SURR/CEN/LINE1)**

Bit	Description
31:8	0's.
7	Bit-15 is 0 in 'Get Amplifier Gain': Read as 0 (No Input Amplifier Mute). Bit-15 is 1 in 'Get Amplifier Gain': Output Amplifier Mute. 0: Unmute 1: Mute (Default=1)
6:0	Bit-15 is 0 in 'Get Amplifier Gain': Read as 0 (No Input Amplifier Gain). Bit-15 is 1 in 'Get Amplifier Gain': Read as 0 (No Output Amplifier Gain).



**Codec Response for NID=18h, 19h and 1Bh (Pin Widget: MIC1/MIC2/LINE2)**

<b>Bit</b>	<b>Description</b>
31:8	0's.
7	Bit-15 is 0 in 'Get Amplifier Gain': Read as 0 (No Input Amplifier Mute). Bit-15 is 1 in 'Get Amplifier Gain': Output Amplifier Mute. 0: Unmute 1: Mute (Default=1)
6:0	Bit-15 is 0 in 'Get Amplifier Gain': Input Amplifier Gain [6:0] specifying the boost from 0dB/10dB/20dB/30dB in 10dB per step (Default=0, 0dB). Bit-15 is 1 in 'Get Amplifier Gain': Read as 0 (No Output Amplifier Gain).

**Codec Response for NID=22h (Sum Widget)**

<b>Bit</b>	<b>Description</b>
31:8	0's.
7	Bit-15 is 0 in 'Get Amplifier Gain': Input Amplifier Mute. 0: Unmute 1: Mute (Default=1 for all index) Bit-15 is 1 in 'Get Amplifier Gain': Read as 0 (No Output Amplifier Mute).
6:0	Bit-15 is 0 in 'Get Amplifier Gain': Read as 0 (No Input Amplifier Gain). Bit-15 is 1 in 'Get Amplifier Gain': Read as 0 (No Output Amplifier Gain).

**Codec Response for NID=23h (Sum Widget)**

<b>Bit</b>	<b>Description</b>
31:8	0's.
7	Bit-15 is 0 in 'Get Amplifier Gain': Input Amplifier Mute. 0: Unmute 1: Mute (Default=1 for all index) Bit-15 is 1 in 'Get Amplifier Gain': Read as 0 (No Output Amplifier Mute).
6:0	Bit-15 is 0 in 'Get Amplifier Gain': Read as 0 (No Input Amplifier Gain). Bit-15 is 1 in 'Get Amplifier Gain': Read as 0 (No Output Amplifier Gain).

**Codec Response to Other NID**

<b>Bit</b>	<b>Description</b>
31:0	Not Supported (returns 00000000h).

## 8.12. Verb – Set Amplifier Gain (Verb ID=3h)

This verb is used to set amplifier gain/attenuation in each widget.

**Table 47. Verb – Set Amplifier Gain (Verb ID=3h)**

Set Command Format

Bit [31:28]	Bit [27:20]	Bit [19:8]	Payload Bit [7:0]
CAd=X	Node ID=Xh	Verb ID=3h	'Set' payload [7:0]

Codec Response Format

Response [31:0]
0's for all nodes

'Set' Payload in Command Bit[15:0]

Bit	Description
15	Set Output Amp. 1: Indicates output amplifier gain will be set
14	Set Input Amp. 1: Indicates input amplifier gain will be set
13	Set Left Amp. 1: Indicates left amplifier gain will be set
12	Set Right Amp. 1: Indicates right amplifier gain will be set
11:8	Index Offset (for input amplifiers on Sum widgets and Selector Widgets). 5-bit index offset in connection list is used to select the input gain that will be set on a Sum or a Selector widget. The index is ignored if the node is not a Sum or a Selector widget, or the 'Set Input Amp' bit is not set.
7	Mute. 0: Unmute 1: Mute ( $-\infty$ gain)
6:0	Gain[6:0]. A 7-bit step value specifying the amplifier gain.

### 8.13. Verb – Get Converter Format (Verb ID=Ah)

**Table 48. Verb – Get Converter Format (Verb ID=Ah)**

Get Command Format				Codec Response Format
<b>Bit [31:28]</b>	<b>Bit [27:20]</b>	<b>Bit [19:16]</b>	<b>Payload Bit [15:0]</b>	<b>Response [31:0]</b>
CAd=X	Node ID=Xh	Verb ID=Ah	0's	Bit[15:0] are converter format

Codec Response for NID=02h~04h, 06h (Output Converters: FRONT, SURR, CEN/LFE DAC, and S/PDIF-OUT).  
 Codec Response for NID=08h and 09h (Input Converters: ADC 08h and ADC 09h)

Bit	Description
31:16	Reserved. Read as 0.
15	Stream Type (TYPE). 0: PCM                    1: Non-PCM
14	Sample Base Rate (BASE). 0: 48kHz                1: 44.1kHz
13:11	Sample Base Rate Multiple (MULT). 000b: *1                001b: *2                010b: *3                011b: *4                100b~111b: Reserved
10:8	Sample Base Rate Divisor (DIV). 000b: /1                001b: /2                010b: /3                011b: /4                100b: /5 101b: /6                110b: /7                111b: /8                Not supported. Always read as 000b.
7	Reserved. Read as 0.
6:4	Bits per Sample (BITS). 000b: 8 bits            001b: 16 bits            010b: 20 bits            011b: 24 bits            100b: 32 bits 101b~111b: Reserved
3:0	Number of Channels. 0: 1 channel            1: 2 channels            2: 3 channels            .....                15: 16 channels

### 8.14. Get Converter Format Support

**Table 49. Get Converter Format Support**

	BASE	MULT	DIV	BITS	Sample Rate
NID=02h (Front DAC)	0	000b,001b	000b	001,010b, 011b	48K, 96K
	1	000b	000b	001,010b, 011b	44.1K
NID=03h (Surr DAC)	0	000b,001b	000b	001,010b, 011b	48K, 96K
	1	000b	000b	001,010b, 011b	44.1K
NID=04h (Cen/Lfe DAC)	0	000b,001b	000b	001,010b, 011b	48K, 96K
	1	000b	000b	001,010b, 011b	44.1K
NID=06h (S/PDIF-OUT)	0	000b,001b	000b	001,010b, 011b	48K, 96K
	1	000b	000b	001,010b, 011b	44.1K
NID=08h (ADC)	0	000b,001b	000b	001b,010b,	48K, 96K
	1	000b	000b	001b,010b,	44.1K
NID=09h (ADC)	0	000b,001b	000b	001b,010b,	48K, 96K
	1	000b	000b	001b,010b,	44.1K

Codec Response for other NID

Bit	Description
31:0	Not Supported (returns 00000000h).

## 8.15. Verb – Set Converter Format (Verb ID=2h)

**Table 50. Verb – Set Converter Format (Verb ID=2h)**

Set Command Format

Bit [31:28]	Bit [27:20]	Bit [19:16]	Payload Bit [15:0]
CAd=X	Node ID=Xh	Verb ID=2h	Set format [15:0]

Codec Response Format

Response [31:0]
0's for all nodes

'Set' Payload in Command Bit[15:0]

Bit	Description
31:16	Reserved. Read as 0.
15	Stream Type (TYPE). 0: PCM                    1: Non-PCM
14	Sample Base Rate (BASE). 0: 48kHz                1: 44.1kHz
13:11	Sample Base Rate Multiple (MULT). 000b: *1                001b: *2                010b: *3                011b: *4                100b~111b: Reserved
10:8	Sample Base Rate Divisor (DIV). 000b: /1                001b: /2                010b: /3                011b: /4                100b: /5 101b: /6                110b: /7                111b: /8
7	Reserved. Read as 0.
6:4	Bits per Sample (BITS). 000b: 8 bits            001b: 16 bits            010b: 20 bits            011b: 24 bits            100b: 32 bits 101b~111b: Reserved
3:0	Number of Channels. 0: 1 channel            1: 2 channels            2: 3 channels            .....                    15: 16 channels

## 8.16. Verb – Get Power State (Verb ID=F05h)

**Table 51. Verb – Get Power State (Verb ID=F05h)**

Get Command Format

Bit [31:28]	Bit [27:20]	Bit [19:8]	Payload Bit [7:0]
CAd=X	Node ID=Xh	Verb ID= F05h	0's

Codec Response Format

Response [31:0]
Power State [7:0]

Codec Response for NID=01h (Audio Function Group)

Bit	Description
31:6	Reserved. Read as 0's.
5:4	PS-Act. Actual Power State [1:0]. 00: Power state is D0                      01: Power state is D1 10: Power state is D2                      11: Power state is D3 PS-Act indicates the actual power state of the referenced node. For Audio Function Group nodes (NID=01h), PS-Act is always equal to PS-Set.
3:2	Reserved. Read as 0's.
1:0	PS-Set. Set Power State [1:0]. 00: Power state is D0                      01: Power state is D1 10: Power state is D2                      11: Power state is D3 PS-Set controls the current power setting of the referenced node.

Codec Response for other NID

Bit	Description
31:0	Not Supported (returns 00000000h).

## 8.17. Verb – Set Power State (Verb ID=705h)

**Table 52. Verb – Set Power State (Verb ID=705h)**

Set Command Format

Bit [31:28]	Bit [27:20]	Bit [19:8]	Payload Bit [7:0]
CAd=X	Node ID=Xh	Verb ID=705h	Power State [7:0]

Codec Response Format

Response [31:0]
0's for all nodes

'Power State' in Command Bit[7:0]

Bit	Description
7:6	Reserved. Read as 0's.
5:4	PS-Act. Actual Power State [1:0]. 00: Power state is D0                      01: Power state is D1 10: Power state is D2                      11: Power state is D3 PS-Act indicates the actual power state of the referenced node.
3:2	Reserved. Read as 0's.
1:0	PS-Set. Set Power State [1:0]. 00: Power state is D0                      01: Power state is D1 10: Power state is D2                      11: Power state is D3

## 8.18. Verb – Get Converter Stream, Channel (Verb ID=F06h)

**Table 53. Verb – Get Converter Stream, Channel (Verb ID=F06h)**

Get Command Format				Codec Response Format
<b>Bit [31:28]</b>	<b>Bit [27:20]</b>	<b>Bit [19:8]</b>	<b>Payload Bit [7:0]</b>	<b>Response [31:0]</b>
CAd=X	Node ID=Xh	Verb ID=F06h	0's	Stream & Channel [7:0]

Codec Response for NID=02h~04h, 06h (Output Converters: FRONT, SURR, CEN/LFE DAC and S/PDIF-OUT)

Codec Response for NID=08h and 09h (Input Converters: ADC 08h and ADC 09h)

Bit	Description
31:8	Reserved. Read as 0's.
7:4	Stream[3:0]. The link stream used by the converter. 0000b is unused, 0001b is stream 1, etc.
3:0	Channel[3:0]. The lowest channel used by the converter. A stereo converter will use the set channel n as well as n+1 for its left and right channel.

Codec Response for other NID

Bit	Description
31:0	Not Supported (returns 00000000h).

## 8.19. Verb – Set Converter Stream, Channel (Verb ID=706h)

**Table 54. Verb – Set Converter Stream, Channel (Verb ID=706h)**

Set Command Format				Codec Response Format
<b>Bit [31:28]</b>	<b>Bit [27:20]</b>	<b>Bit [19:8]</b>	<b>Payload Bit [7:0]</b>	<b>Response [31:0]</b>
CAd=X	Node ID=Xh	Verb ID=706h	Stream & Channel [7:0]	0's for all nodes

'Stream and Channel' in Command Bit[7:0]

Bit	Description
31:8	Reserved. Read as 0's.
7:4	Set Stream[3:0]. The link stream used by the converter. 0000b is stream 0, 0001b is stream 1, etc.
1:0	Set Channel[3:0]. The lowest channel used by the converter. A stereo converter will use the set channel n as well as n+1 for its left and right channel.

## 8.20. Verb – Get Pin Widget Control (Verb ID=F07h)

**Table 55. Verb – Get Pin Widget Control (Verb ID=F07h)**

Get Command Format

Bit [31:28]	Bit [27:20]	Bit [19:8]	Payload Bit [7:0]
CAd=X	Node ID=Xh	Verb ID=F07h	0's

Codec Response Format

Response [31:0]
Pin Control [7:0]

Codec Response for NID=14h, 15h, 16h, 18h, 19h, 1Ah, 1Bh, 1Ch, 1Dh, 1Eh.

(Pin Widget: FRONT, SURR, CENLFE, MIC1, MIC2, LINE1, LINE2, CD-IN, PCBEEP, S/PDIF-OUT)

Bit	Description
31:8	Reserved. Read as 0's.
7	H-Phn Enable. 0: Disabled 1: Enabled <i>Note: Only NID=14h (FRONT), 19h (MIC2), and 1Bh (LINE2) support headphone amplifier.</i>
6	Out Enable (Output Buffet Enable, EN_OBUF for an I/O unit). 0: Disabled 1: Enabled <i>Note: NID=1Ch (CD-IN) and 1Dh (PCBEEP) do not support output and are always read 0.</i>
5	In Enable (Input Buffer Enable, EN_IBUF for an I/O unit). 0: Disabled 1: Enabled <i>Note: NID=1Eh (S/PDIF-OUT) does not support output and is always read 0.</i>
4:3	Reserved.
2:0	VrefEn (Vrefout Enable Control). 000b: Hi-Z (Disabled, default for all) 001b: 50% of AVDD (The ALC662 supports 2.5V reference output when AVDD is 5V) 010b: Ground 0V 011b: Reserved 100b: 80% of AVDD (The ALC662 supports 3.2V reference output when AVDD is 5V) 101b: 100% of AVDD 110b~111b: Reserved <i>Note: Only NID=18h, 19h, and 1Bh support reference output, other nodes will ignore this verb and respond with 0.</i>

Codec Response for other NID

Bit	Description
31:0	Not Supported (returns 00000000h).

## 8.21. Verb – Set Pin Widget Control (Verb ID=707h)

**Table 56. Verb – Set Pin Widget Control (Verb ID=707h)**

Set Command Format

Bit [31:28]	Bit [27:20]	Bit [19:8]	Payload Bit [7:0]
CAd=X	Node ID=Xh	Verb ID=707h	Pin Control [7:0]

Codec Response Format

Response [31:0]
0's for all nodes

'Pin Control' in command [7:0]: (NID=14h, 15h, 16h, 18h, 19h, 1Ah, 1Bh, 1Ch, 1Dh, 1Eh)

(Pin Widget: FRONT, SURR, CENLFE, MIC1, MIC2, LINE1, LINE2, CD-IN, PCBEEP, S/PDIF-OUT)

Bit	Description
31:8	Reserved. Read as 0's.
7	H-Phn Enable. 0: Disabled 1: Enabled <i>Note: Only NID=14h (FRONT), 19h (MIC2), and 1Bh (LINE2) support headphone amplifier.</i>
6	Out Enable (Output Buffet Enable, EN_OBUF for an I/O unit). 0: Disabled 1: Enabled <i>Note: NID=1Ch (CD-IN) and 1Dh(PCBEEP) do not support output and are always read 0.</i>
5	In Enable (Input Buffer Enable, EN_IBUF for an I/O unit). 0: Disabled 1: Enabled <i>Note: NID=1Eh (S/PDIF-OUT) does not support output and is always read 0.</i>
4:3	Reserved.
2:0	VrefEn (Vrefout Enable Control). 000b: Hi-Z (Disabled, default for all) 001b: 50% of AVDD 010b: Ground 0V 011b: Reserved 100b: 80% of AVDD 101b: 100% of AVDD 110b~111b: Reserved <i>Note: Only NID=18h, 19h, and 1Bh support reference output. Other nodes will ignore this verb and respond with 0.</i>



## 8.22. Verb – Get Unsolicited Response Control (Verb ID=F08h)

Determines whether a widget is enabled to send an unsolicited response. An HDA codec can use an unsolicited response to inform software of a real time event.

**Table 57. Verb – Get Unsolicited Response Control (Verb ID=F08h)**

Get Command Format

Bit [31:28]	Bit [27:20]	Bit [19:8]	Payload Bit [7:0]
CAd=X	Node ID=Xh	Verb ID= F08h	0's

Codec Response Format

Response [31:0]
32-bit Response

Codec Response for NID=01h (GPIO), 14h~16h, 18h~1Bh (Port jack detection)

Bit	Description
31:8	Reserved. Read as 0's.
7	Unsolicited Response is Enabled. 0: Disabled                                    1: Enabled
6:4	Reserved. Read as 0's.
3:0	Assigned Tag for Unsolicited Response. The tag[3:0] is assigned by software to determine which widget generates unsolicited responses.

Codec Response for other NID

Bit	Description
31:0	Not Supported (returns 00000000h).

## 8.23. Verb – Set Unsolicited Response Control (Verb ID=708h)

Enable a widget to generate an unsolicited response.

**Table 58. Verb – Set Unsolicited Response Control (Verb ID=708h)**

Set Command Format

Bit [31:28]	Bit [27:20]	Bit [19:8]	Payload Bit [7:0]
CAd=X	Node ID=Xh	Verb ID=708h	EnableUnsol [7:0]

Codec Response Format

Response [31:0]
0's for all nodes

'EnableUnsol' in Command Bit [7:0]

Bit	Description
31:8	Reserved. Read as 0's.
7	Unsolicited Response. 0: Disable                                    1: Enable
6	Reserved. Read as 0's.
5:0	Tag for Unsolicited Responses. Tag[5:0] is defined by software to assign a 6-bit tag for nodes that are enabled to generate unsolicited responses.

## 8.24. Verb – Get Pin Sense (Verb ID=F09h)

Returns the Presence Detect status and the impedance of a device attached to the pin.

**Table 59. Verb – Get Pin Sense (Verb ID=F09h)**

Get Command Format

Bit [31:28]	Bit [27:20]	Bit [19:8]	Payload Bit [7:0]
CAd=X	Node ID=Xh	Verb ID= F09h	0's

Codec Response Format

Response [31:0]
32-bit Response

Codec Response for NID=14h, 15h, 16h, 18h, 19h, 1Ah, 1Bh

(Pin Widget: FRONT, SURR, CENLFE, MIC1, MIC2, LINE1, LINE2)

Bit	Description
31	Presence Detect Status. 0: No device is attached to the pin 1: Device is attached to the pin
30:0	Measured Impedance. The ALC662 does not support hardware impedance detect. This field is read as 0s.

Codec Response for other NID

Bit	Description
31:0	Not Supported (returns 00000000h).

## 8.25. Verb – Execute Pin Sense (Verb ID=709h)

**Table 60. Verb – Execute Pin Sense (Verb ID=709h)**

Command Format

Bit [31:28]	Bit [27:20]	Bit [19:8]	Payload Bit [7:0]
CAd=X	Node ID=Xh	Verb ID= 709h	Right Channel[0]

Codec Response Format

Response [31:0]
0's for all nodes

'Payload' in Command Bit[7:0] (for NID=14h, 15h, 16h, 18h, 19h, 1Ah, 1Bh)

Bit	Description
7:1	Reserved. Read as 0's.
0	Right (Ring) Channel Select. 0: Sense Left channel (Tip) 1: Sense Right channel (Ring) The ALC662 does not support hardware impedance detect and will ignore this control bit.

## 8.26. Verb – Get Configuration Default (Verb ID=F1Ch/F1Dh/F1Eh/F1Fh)

Read the 32-bit sticky register for each Pin Widget configured by software.

**Table 61. Verb – Get Configuration Default (Verb ID=F1Ch/F1Dh/F1Eh/F1Fh)**

Get Command Format				Codec Response Format
<b>Bit [31:28]</b>	<b>Bit [27:20]</b>	<b>Bit [19:8]</b>	<b>Payload Bit [7:0]</b>	<b>Response [31:0]</b>
CAd=X	Node ID=Xh	Verb ID= F1Ch	0's	32-bit Response

Codec Response for NID=14h, 15h, 16h, 18h, 19h, 1Ah, 1Bh, 1Ch, 1Dh, 1Eh  
(Pin Widget: FRONT, SURR, CENLFE, MIC1, MIC2, LINE1, LINE2, CD-IN, PCBEEP, S/PDIF-OUT)

Bit	Description
31:0	32-bit configuration information for each pin widget.

*Note: The 32-bit registers for each Pin Widget are sticky and will not be reset by a LINK Reset or Codec Reset (Function Reset Verb).*

## 8.27. Verb – Set Configuration Default Bytes 0, 1, 2, 3 (Verb ID=71Ch/71Dh/71Eh/71Fh for Bytes 0, 1, 2, 3)

The BIOS can use this verb to figure out the default conditions (e.g., placement and expected default device) for the Pin Widgets NID=0B~0Fh, 10h, 11h, 1Fh, 20h, and 12h.

**Table 62. Verb – Set Configuration Default Bytes 0, 1, 2, 3  
(Verb ID=71Ch/71Dh/71Eh/71Fh for Bytes 0, 1, 2, 3)**

Set Command Format				Codec Response Format
<b>Bit [31:28]</b>	<b>Bit [27:20]</b>	<b>Bit [19:8]</b>	<b>Payload Bit [7:0]</b>	<b>Response [31:0]</b>
CAd=X	Node ID=Xh	Verb ID=71Ch, 71Dh, 71Eh, 71Fh	Label [7:0]	0's for all nodes

*Note: Supported by Pin Widget NID=14h~16h, 18h~1Bh, 1Ch, 1Dh, and 1Eh. Other widgets will ignore this verb.*

Codec Response for All NID

Bit	Description
31:0	0's.

## 8.28. Verb – Get BEEP Generator (Verb ID=F0Ah)

**Table 63. Verb – Get BEEP Generator (Verb ID= F0Ah)**

Get Command Format

Bit [31:28]	Bit [27:20]	Bit [19:8]	Payload Bit [7:0]
CAd=X	Node ID=01h	Verb ID= F1Bh	0's

Codec Response Format

Response [31:0]
Divider [7:0]

'Response' for NID=01h

Bit	Description
31:8	Reserved.
7:0	Frequency Divider, F[7:0]. The internal BEEP frequency is the result of dividing the 48kHz clock by 4 times the number specified in F[7:0]. The lowest tone is $48\text{kHz}/(255*4)=47\text{Hz}$ . The highest tone is $48\text{kHz}/(1*4)=12\text{kHz}$ . A value of 00h in F[7:0] disables the internal BEEP generator and allows external PCBEEP input.

Codec Response for Other NID

Bit	Description
31:0	0's.

## 8.29. Verb – Set BEEP Generator (Verb ID=70Ah)

**Table 64. Verb – Set BEEP Generator (Verb ID= 70Ah)**

Set Command Format

Bit [31:28]	Bit [27:20]	Bit [19:8]	Payload Bit [7:0]
CAd=X	Node ID=01h	Verb ID=71Bh	Divider [7:0]

Codec Response Format

Response [31:0]
0's for all nodes

'Divider' in Set Command

Bit	Description
31:8	Reserved.
7:0	Frequency Divider, F[7:0]. The internal BEEP frequency is the result of dividing the 48kHz clock by 4 times the number specified in F[7:0]. The lowest tone is $48\text{kHz}/(255*4)=47\text{Hz}$ . The highest tone is $48\text{kHz}/(1*4)=12\text{kHz}$ . A value of 00h in F[7:0] disables the internal BEEP generator and allows external PCBEEP input.

*Note: All nodes except BEEP generator (NID=01h) will ignore this verb.*

Codec Response for All NID

Bit	Description
31:0	0's.

### 8.30. Verb – Get GPIO Data (Verb ID= F15h)

**Table 65. Verb – Get GPIO Data (Verb ID= F15h)**

Get Command Format

Bit [31:28]	Bit [27:20]	Bit [19:8]	Payload Bit [7:0]
CAd=X	Node ID=01h	Verb ID=F15h	0's

Codec Response Format

Response [31:0]
32-bit Response

Codec Response for NID=01h (Audio Function Group)

Bit	Description
31:2	Reserved.
1:0	GPIO[1:0] Data. The value written (output) or sensed (input) on the corresponding pin if it is enabled.

Codec Response for Other NID

Bit	Description
31:0	0's.

### 8.31. Verb – Set GPIO Data (Verb ID= 715h)

**Table 66. Verb – Set GPIO Data (Verb ID= 715h)**

Set Command Format

Bit [31:28]	Bit [27:20]	Bit [19:8]	Payload Bit [7:0]
CAd=X	Node ID=01h	Verb ID=715h	Data [7:0]

Codec Response Format

Response [31:0]
0's for all nodes

'Data' in Set command for NID=01h (Audio Function Group)

Bit	Description
31:2	Reserved.
1:0	GPIO[1:0] Output Data. The value written determines the value driven on a pin that is configured as an output pin.

Codec Response for All NID

Bit	Description
31:0	0's.

### 8.32. Verb – Get GPIO Enable Mask (Verb ID=F16h)

**Table 67. Verb – Get GPIO Enable Mask (Verb ID= F16h)**

Get Command Format

Bit [31:28]	Bit [27:20]	Bit [19:8]	Payload Bit [7:0]
CAd=X	Node ID=01h	Verb ID=F16h	0's

Codec Response Format

Response [31:0]
EnableMask [7:0]

Codec Response for NID=01h (Audio Function Group)

Bit	Description
31:2	Reserved.
1:0	GPIO[1:0] Enable Mask. 0: The corresponding GPIO pin is disabled and is in Hi-Z state 1: The corresponding GPIO pin is enabled. Its behavior is determined by the GPIO direction control

*Note: All nodes except Audio Function Group (NID=01h) will ignore this verb.*

Codec Response for Other NID

Bit	Description
31:0	0's.

### 8.33. Verb – Set GPIO Enable Mask (Verb ID=716h)

**Table 68. Verb – Set GPIO Enable Mask (Verb ID=716h)**

Set Command Format

Bit [31:28]	Bit [27:20]	Bit [19:8]	Payload Bit [7:0]
CAd=X	Node ID=01h	Verb ID=716h	Enable Mask [7:0]

Codec Response Format

Response [31:0]
0's for all nodes

Codec Response for NID=01h (Audio Function Group)

Bit	Description
31:2	Reserved.
1:0	GPIO[1:0] Enable Mask. 0: The corresponding GPIO pin is disabled and is in Hi-Z state 1: The corresponding GPIO pin is enabled. Its behavior is determined by the GPIO direction control

*Note: All nodes except Audio Function Group (NID=01h) will ignore this verb.*

Codec Response for All NID

Bit	Description
31:0	0's.

### 8.34. Verb – Get GPIO Direction (Verb ID=F17h)

**Table 69. Verb – Get GPIO Direction (Verb ID=F17h)**

Get Command Format

Bit [31:28]	Bit [27:20]	Bit [19:8]	Payload Bit [7:0]
CAd=X	Node ID=01h	Verb ID=F17h	0's

Codec Response Format

Response [31:0]
Direction [7:0]

Codec Response for NID=01h (Audio Function Group)

Bit	Description
31:2	Reserved.
1:0	GPIO[1:0] Direction Control. 0: The corresponding GPIO pin is configured as an input 1: The corresponding GPIO pin is configured as an output

*Note: All nodes except Audio Function Group (NID=01h) will ignore this verb.*

Codec Response for Other NID

Bit	Description
31:0	0's.

### 8.35. Verb – Set GPIO Direction (Verb ID=717h)

**Table 70. Verb – Set GPIO Direction (Verb ID=717h)**

Set Command Format

Bit [31:28]	Bit [27:20]	Bit [19:8]	Payload Bit [7:0]
CAd=X	Node ID=01h	Verb ID=717h	Direction [7:0]

Codec Response Format

Response [31:0]
0's for all nodes

Codec Response for NID=01h (Audio Function Group)

Bit	Description
31:2	Reserved.
1:0	GPIO[1:0] Direction Control. 0: The corresponding GPIO pin is configured as an input 1: The corresponding GPIO pin is configured as an output

*Note: All nodes except Audio Function Group (NID=01h) will ignore this verb.*

Codec Response for Other NID

Bit	Description
31:0	0's.

### 8.36. Verb – Get GPIO Unsolicited Response Enable Mask (Verb ID=F19h)

**Table 71. Verb – Get GPIO Unsolicited Response Enable Mask (Verb ID=F19h)**

Get Command Format				Codec Response Format
Bit [31:28]	Bit [27:20]	Bit [19:8]	Payload Bit [7:0]	Response [31:0]
CAd=X	Node ID=01h	Verb ID=F19h	0's	UnsolEnable [7:0]

Codec Response for NID=01h (Audio Function Group)

Bit	Description
31:2	Reserved.
1:0	GPIO[1:0] Unsolicited Enable Mask. 0: Unsolicited response will not be sent on link 1: Unsolicited response will be sent on link when state of corresponding GPIO has been changed

Note: All nodes except Audio Function Group (NID=01h) will ignore this verb.

Codec Response for Other NID

Bit	Description
31:0	0's.

### 8.37. Verb – Set GPIO Unsolicited Response Enable Mask (Verb ID=719h)

**Table 72. Verb – Set GPIO Unsolicited Response Enable Mask (Verb ID=719h)**

Set Command Format				Codec Response Format
Bit [31:28]	Bit [27:20]	Bit [19:8]	Payload Bit [7:0]	Response [31:0]
CAd=X	Node ID=01h	Verb ID=719h	UnsolEnable [7:0]	0's for all nodes

Codec Response for NID=01h (Audio Function Group)

Bit	Description
31:2	Reserved.
1:0	GPIO[1:0] Unsolicited Enable Mask. 0: Unsolicited response will not be sent on link 1: Unsolicited response will be sent on link when state of corresponding GPIO has been changed

Note 1: All nodes except the Audio Function Group (NID=01h) will ignore this verb.

Note 2: The unsolicited response of corresponding GPIO is enabled when it's 'Enable Mask' and Verb- 'Unsolicited Response' for NID=01h are enabled.

Codec Response for Other NID

Bit	Description
31:0	0's.



### 8.38. Verb – Get Digital Converter Control 1 & Control 2 (Verb ID= F0Dh, F0Eh)

**Table 73. Verb – Get Digital Converter Control 1 & Control 2 (Verb ID= F0Dh, F0Eh)**

Get Command Format				Codec Response Format
Bit [31:28]	Bit [27:20]	Bit [19:8]	Payload Bit [7:0]	Response [31:0]
CAd=X	Node ID=06h	Verb ID=F0Dh/F0Eh	0's	Bit[31:16]=0's, Bit[15:0] are SIC bit

NID=06h (S/PDIF-OUT Converter) Response to 'Get verb' – F0Dh (Control for SIC bit[15:0])

Bit	Description – SIC (S/PDIF IEC Control) Bit[7:0]
31:16	Read as 0's.
15	Reserved. Read as 0's.
14:8	CC[6:0] (Category Code).
7	LEVEL (Generation Level).
6	PRO (Professional or Consumer Format). 0: Consumer format 1: Professional format
5	/AUDIO (Non-Audio Data Type). 0: PCM data 1: AC3 or other digital non-audio data
4	COPY (Copyright). 0: Asserted 1: Not asserted
3	PRE (Pre-Emphasis). 0: None 1: Filter pre-emphasis is 50/15 microseconds
2	VCFG for Validity Control (control V bit and data in Sub-Frame).
1	V for Validity Control (control V bit and data in Sub-Frame).
0	Digital Enable. DigEn. 0: OFF 1: ON

Codec Response for Other NID

Bit	Description
31:0	0's.

### 8.39. Verb – Set Digital Converter Control 1 & Control 2 (Verb ID=70Dh, 70Eh)

**Table 74. Verb – Set Digital Converter Control 1 & Control 2 (Verb ID=70Dh, 70Eh)**

Set Command Format (Verb ID=70Dh, Set Control 1)

Bit [31:28]	Bit [27:20]	Bit [19:8]	Payload Bit [7:0]
CAd=X	Node ID=06h	Verb ID=70Dh	SIC [7:0]

Codec Response Format

Response [31:0]
0's

Set Command Format (Verb ID=70Eh, Set Control 2)

Bit [31:28]	Bit [27:20]	Bit [19:8]	Payload Bit [7:0]
CAd=X	Node ID=06h	Verb ID=70Eh	SIC [15:8]

Codec Response Format

Response [31:0]
0's

'Payload' in Set Control 1 for NID=06h (S/PDIF-OUT Converter)

Bit	Description – SIC (S/PDIF IEC Control) Bit[7:0]
7	LEVEL (Generation Level).
6	PRO (Professional or Consumer Format). 0: Consumer format 1: Professional format
5	/AUDIO (Non-Audio Data Type). 0: PCM data 1: AC3 or other digital non-audio data
4	COPY (Copyright). 0: Asserted 1: Not asserted
3	PRE (Pre-Emphasis). 0: None 1: Filter pre-emphasis is 50/15 microseconds
2	VCFG for Validity Control (control V bit and data in Sub-Frame).
1	V for Validity Control (control V bit and data in Sub-Frame).
0	Digital Enable. DigEn. 0: OFF 1: ON

'Payload' in Set Control 2 for NID=06h (S/PDIF-OUT Converter)

Bit	Description – SIC (S/PDIF IEC Control) Bit[7:0]
7	Reserved. Read as 0's.
6:0	CC[6:0] (Category Code).

### 8.40. Verb – Get Subsystem ID [31:0] (Verb ID=F20h/F21h/D22h/F23h)

32-bit Read/Write register for Audio Function Group (NID=01h)

**Table 75. Verb – Get Subsystem ID [31:0] (Verb ID=F20h/F21h/F22h/F23h)**

Get Command Format

Bit [31:28]	Bit [27:20]	Bit [19:8]	Payload Bit [7:0]
CAd = X	Node ID=01h	Verb ID=F20h	0s

Codec Response Format

Response [31:0]
32-bit Response

Codec Response for NID=01h

Bit	Description
31:16	Subsystem ID[23:8] (Default=10ECh).
15:8	Subsystem ID[7:0] (Default=06h).
7:0	Assembly ID[7:0] (Default=62h).

### 8.41. Verb – Set Subsystem ID [31:0] (Verb ID=723h for [31:24], 722h for [23:16], 721h for [15:8], 720h for [7:0])

**Table 76. Verb – Set Subsystem ID [31:0]  
(Verb ID=723h for [31:24], 722h for [23:16], 721h for [15:8], 720h for [7:0])**

Set Command Format

Bit [31:28]	Bit [27:20]	Bit [19:8]	Payload Bit [7:0]
CAd = X	Node ID=01h	Verb ID=723h, 722h, 721h, 720h	Label [7:0]

Codec Response Format

Response [31:0]
0s for all nodes

Codec Response for all NID

Bit	Description
31:0	0s.



## 8.44. Verb – Function Reset (Verb ID=7FFh)

**Table 79. Verb – Function Reset (Verb ID=7FFh)**

Command Format (NID=01h)

Bit [31:28]	Bit [27:20]	Bit [19:8]	Payload Bit [7:0]
CAd=X	Node ID=01h	Verb ID=7FFh	0's

Codec Response Format

Response [31:0]
0's

Codec Response

Bit	Description
31:0	Reserved. Read as 0's.

*Note: The Function Reset command causes all widgets to return to their power-on default state.*

## 9. Electrical Characteristics

### 9.1. DC Characteristics

#### 9.1.1. Absolute Maximum Ratings

**Table 80. Absolute Maximum Ratings**

Parameter	Symbol	Minimum	Typical	Maximum	Units
Power Supply					
Digital Power for Core	DVDD	2.7	3.3	3.6	V
Digital Power for HDA Link	DVDD-IO*	1.5	3.3	3.6	V
Analog	AVDD**	3.0	5.0	5.5	V
Ambient Operating Temperature	Ta	0	-	+70	°C
Storage Temperature	Ts	-	-	+125	°C
<b>ESD (Electrostatic Discharge)</b>					
		Susceptibility Voltage			
Digital Pins		3500V			
Analog Pins		4000V			

\*: The digital link power DVDD-IO must be lower than the digital core power DVDD.

\*\* : The standard testing condition before shipping is AVDD = 5.0V unless specified. Customers designing with a different AVDD should contact Realtek technical support representatives for special testing support.

#### 9.1.2. Threshold Voltage

DVDD=3.3V±5%, T<sub>ambient</sub>=25°C, with 50pF external load.

**Table 81. Threshold Voltage**

Parameter	Symbol	Minimum	Typical	Maximum	Units
Input Voltage Range	V <sub>in</sub>	-0.30	-	DVDD +0.30	V
Low Level Input Voltage (HDA Link)	V <sub>IL</sub>	-	-	0.30*DVDDIO	V
High Level Input Voltage (HDA Link)	V <sub>IH</sub>	0.65*DVDDIO	-	-	V
Low Level Input Voltage (S/PDIF-OUT)	V <sub>IL</sub>	-	-	0.44*DVDD (1.45)	V
High Level Input Voltage (S/PDIF-OUT)	V <sub>IH</sub>	0.56*DVDD (1.85)	-	-	V
High Level Output Voltage	V <sub>OH</sub>	0.9*DVDD	-	-	V
Low Level Output Voltage	V <sub>OL</sub>	-	-	0.1*DVDD	V
Input Leakage Current	-	-10	-	10	μA
Output Leakage Current (Hi-Z)	-	-10	-	10	μA
Output Buffer Drive Current	-	-	5	-	mA
Internal Pull Up Resistance	-	-	50k	100k	Ω

### 9.1.3. Digital Filter Characteristics

**Table 82. Digital Filter Characteristics**

Filter	Symbol	Minimum	Typical	Maximum	Units
ADC Lowpass Filter	Passband	0	-	0.45*Fs	kHz
	Stopband	0.60*Fs	-	-	kHz
	Stopband Rejection	-	-76.0	-	dB
	Passband Frequency Response	-	±0.05	-	dB
DAC Lowpass Filter	Passband	0	-	0.45*Fs	kHz
	Stopband	0.60*Fs	-	-	kHz
	Stopband Rejection	-	-78.5	-	dB
	Passband Frequency Response	-	±0.05	-	dB

Note:  $F_s$ =Sample rate.

### 9.1.4. S/PDIF Output Characteristics

DVDD= 3.3V,  $T_{\text{ambient}}=25^{\circ}\text{C}$ , with 75Ω external load.

**Table 83. S/PDIF Output Characteristics**

Parameter	Symbol	Minimum	Typical	Maximum	Units
S/PDIF-OUT High Level Output	$V_{OH}$	3.0	3.3	-	V
S/PDIF-OUT Low Level Output	$V_{OL}$	-	0	0.3	V

## 9.2. AC Characteristics

### 9.2.1. Link Reset and Initialization Timing

**Table 84. Link Reset and Initialization Timing**

Parameter	Symbol	Minimum	Typical	Maximum	Units
RESET# Active Low Pulse Width	$T_{RST}$	1.0	-	-	$\mu\text{s}$
RESET# Inactive to BCLK Startup Delay for PLL Ready Time	$T_{PLL}$	20	-	-	$\mu\text{s}$
SDI Initialization Request	$T_{FRAME}$	-	-	1	Frame Time

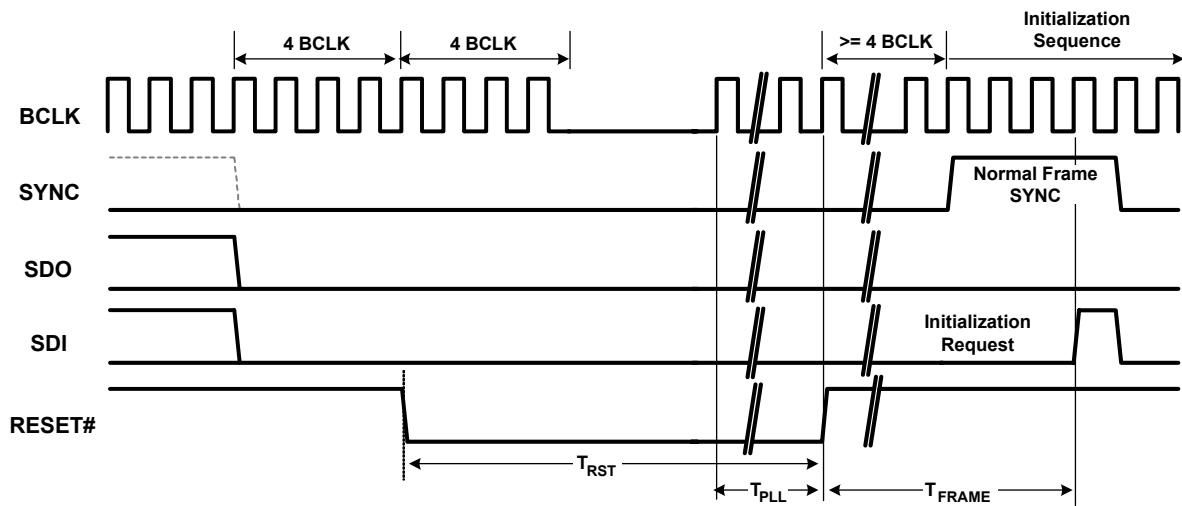
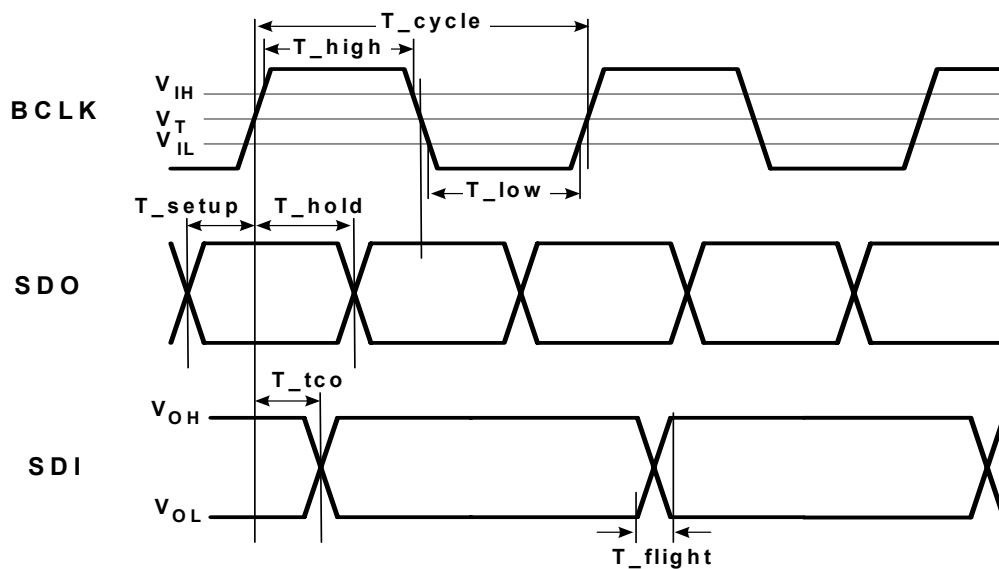

**Figure 14. Link Reset and Initialization Timing**



## 9.2.2. Link Timing Parameters at the Codec

**Table 85. Link Timing Parameters at the Codec**

Parameter	Symbol	Minimum	Typical	Maximum	Units
BCLK Frequency	-	-	24.0	-	MHz
BCLK Period	$T_{\text{cycle}}$	-	41.67	-	ns
BCLK Jitter	$T_{\text{jitter}}$	-	-	2.0	ns
BCLK High Pulse Width	$T_{\text{high}}$	18.75 (45%)	-	22.91 (55%)	ns (%)
BCLK Low Pulse Width	$T_{\text{low}}$	18.75 (45%)	-	22.91 (55%)	ns (%)
SDO Setup Time at Both Rising and Falling Edge of BCLK	$T_{\text{setup}}$	2.1	-	-	ns
SDO Hold Time at Both Rising and Falling Edge of BCLK	$T_{\text{hold}}$	2.1	-	-	ns
SDI Valid Time After Rising Edge of BCLK (1:50pF external load)	$T_{\text{tco}}$	-	7.5	8.0	ns
SDI Flight Time	$T_{\text{flight}}$	-	2.0	-	ns

**Figure 15. Link Signal Timing**

### 9.2.3. S/PDIF Output Timing

**Table 86. S/PDIF Output Timing**

Parameter	Symbol	Minimum	Typical	Maximum	Units
S/PDIF-OUT Frequency	-	-	3.072	-	MHz
S/PDIF-OUT Period	$T_{\text{cycle}}$	-	325.6	-	ns
S/PDIF-OUT Jitter	$T_{\text{jitter}}$	-	-	4	ns
S/PDIF-OUT High Level Width	$T_{\text{High}}$	156.2 (48%)	162.8 (50%)	169.2 (52%)	ns (%)
S/PDIF-OUT Low Level Width	$T_{\text{Low}}$	156.2 (48%)	162.8 (50%)	169.2 (52%)	ns (%)
S/PDIF-OUT Rising Time	$T_{\text{rise}}$	-	2.0	-	ns
S/PDIF-OUT Falling Time	$T_{\text{fall}}$	-	2.0	-	ns

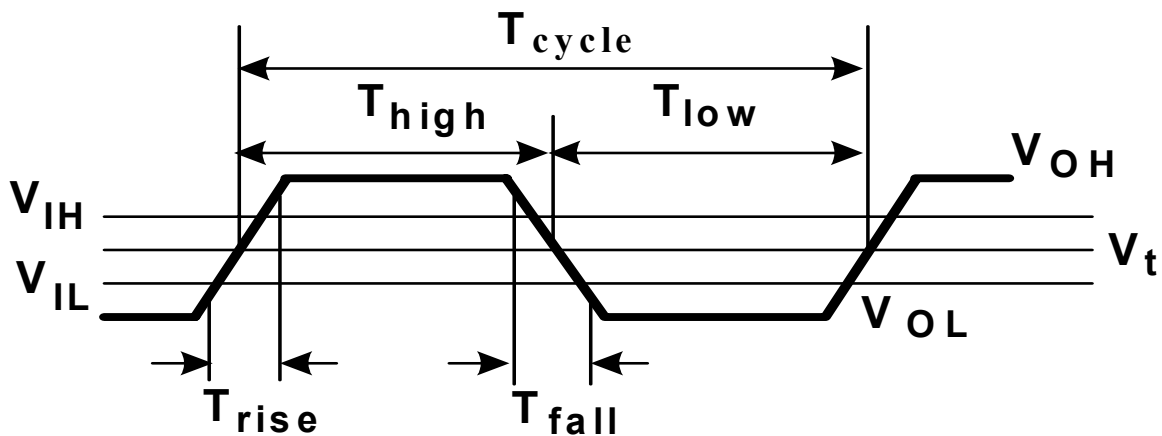
**Figure 16. Output Timing**

### 9.2.4. Test Mode

Codec test mode and Automatic Test Equipment (ATE) mode are not supported.

### 9.3. Analog Performance

- Standard Test Conditions
- Tambient=25 oC, DVDD= 3.3V ±5%, AVDD=5.0V±5%
  - 1kHz input sine wave; Sampling frequency=48kHz; 0dB=1Vrms
  - 10KΩ/50pF load; Test bench Characterization BW: 10Hz~22kHz

**Table 87. Analog Performance**

Parameter	Min	Typ	Max	Units
Full Scale Input Voltage				
All Inputs (Gain=0dB)	-	1.6	-	Vrms
ADC	-	1.4	-	Vrms
Full Scale Output Voltage				
DAC	-	1.4	-	Vrms
S/N (A Weighted)				
ADC	-	90	-	dB FSA
DAC	-	98	-	dB FSA
Headphone Amplifier	-	98	-	dBFS A
THD+N (-3dB Test Signal)				
ADC	-	-85	-	dB FS
DAC	-	-92	-	dB FS
Headphone Amplifier (32Ω Load)	-	-75	-	dB FS
THD+N (-1dB Test Signal for ALC662-VC)				
ADC	-	-83	-	dB FS
DAC	-	-90	-	dB FS
Magnitude Response				
ADC (-3dB lower edge, -1dB higher edge)*	0	-	>20,000	Hz
DAC (-3dB lower edge, -1dB higher edge)*	0	-	>20,000	Hz
Passband ripple for DAC and ADC (ALC662)	-0.20	-	+0.20	dB
Passband ripple for DAC and ADC (ALC662-VC)	-0.02	-	+0.02	dB
Power Supply Rejection Ratio	-	-40	-	dB
Total Out-of-Band Noise (28.8kHz~100kHz)	-	-60	-	dB
Crosstalk Between Output Channel (1kHz/20kHz)	-	-	-90/-80	dB
Output Noise Level During System Activity	-	-	110	dB
Output Inter-Channel Phase Delay	-	-	0.2	Degree
Input Impedance (Gain=0dB)	-	40	-	KΩ
Output Impedance				
Line Output	-	100	-	Ω
Amplified Output	-	1	2	Ω
Power Supply Current (Normal Operation)				
AVDD=5V/DVDD=3.3V	-	38/23	-	mA
Power Supply Current (Power Down Mode)				
AVDD=5V/DVDD=3.3V	-	0.4/1.1	-	mA
VREFOUTx Output Voltage (AVDD=5.0V)	-	2.5	3.2	V
VREFOUTx Output Current (AVDD=5.0V)	-	5	-	mA

\*: The higher edge of magnitudes for DAC and ADC are -0.6dB@20,000Hz.

## 10. Application Circuits

The ALC662 series is fully pin to pin compatible with the ALC88x series. Please contact Realtek to get the latest application circuits. To get the best compatibility in hardware design and software driver, any modifications should be confirmed by Realtek. Realtek may update the latest application circuits onto our website ([www.realtek.com.tw](http://www.realtek.com.tw)) without modifying this data sheet.

### 10.1. Filter Connection

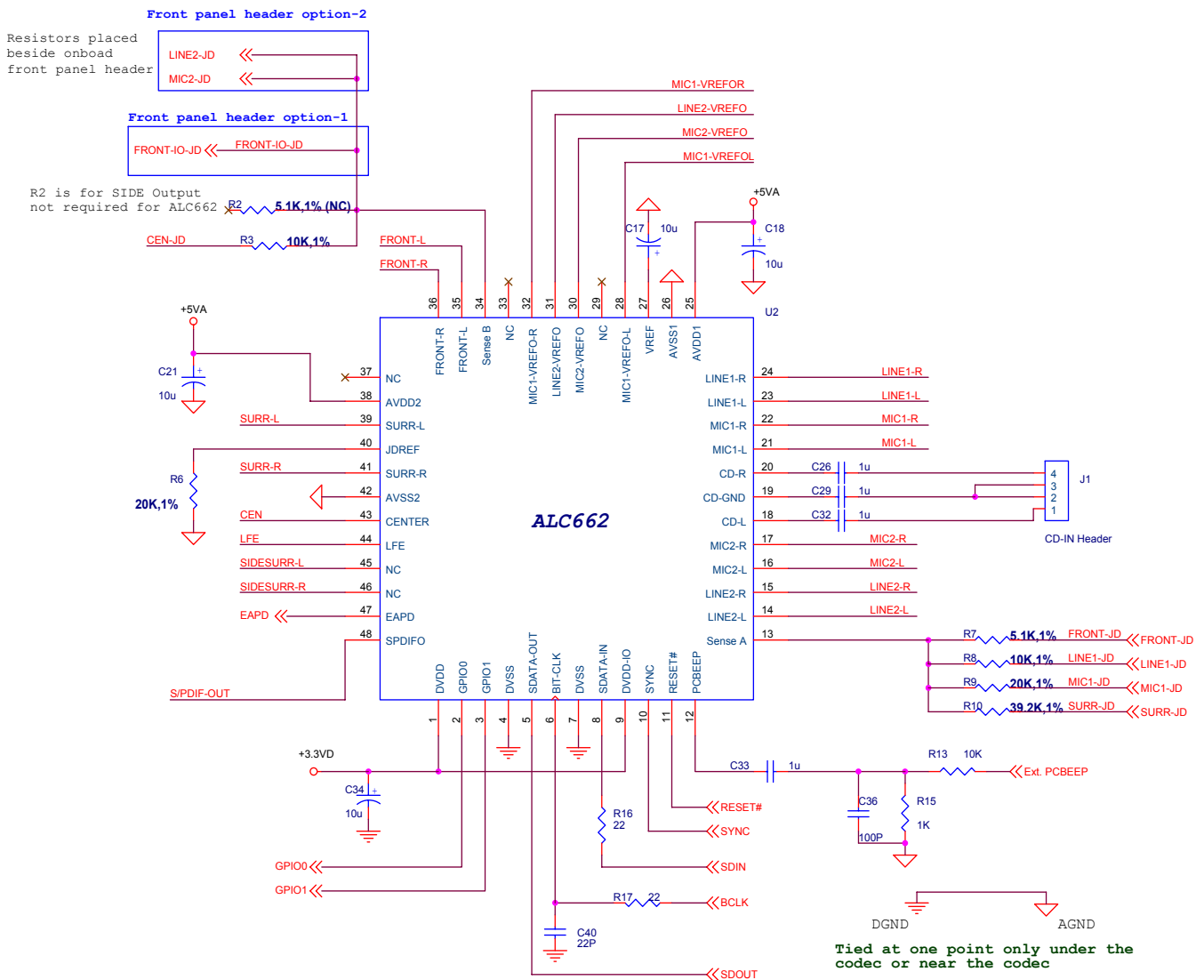

## 10.2. Onboard Front Panel Header Connection and Front Panel I/O

Option 1: Follow Intel's HD Audio front panel header design  
(Two ports must be in the same jack detect group)

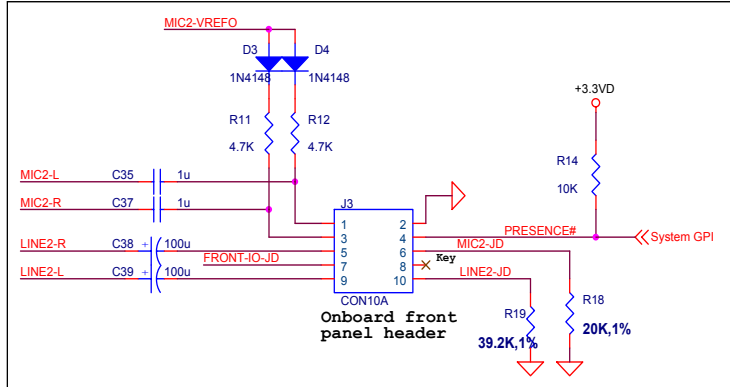

Option 2: A more flexible front panel header  
(Each port can be in different jack detect group)

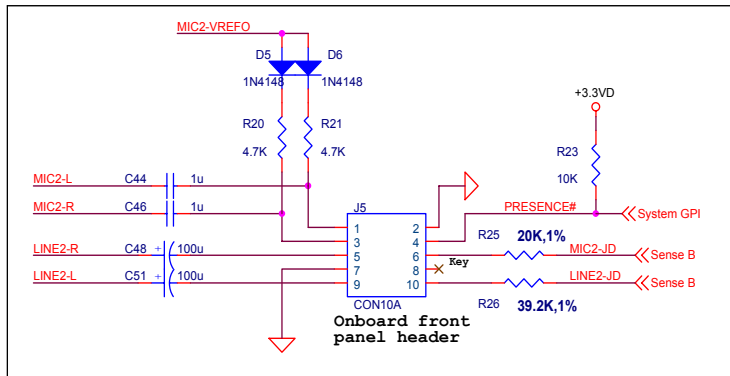

HD Audio Front Panel I/O Cable

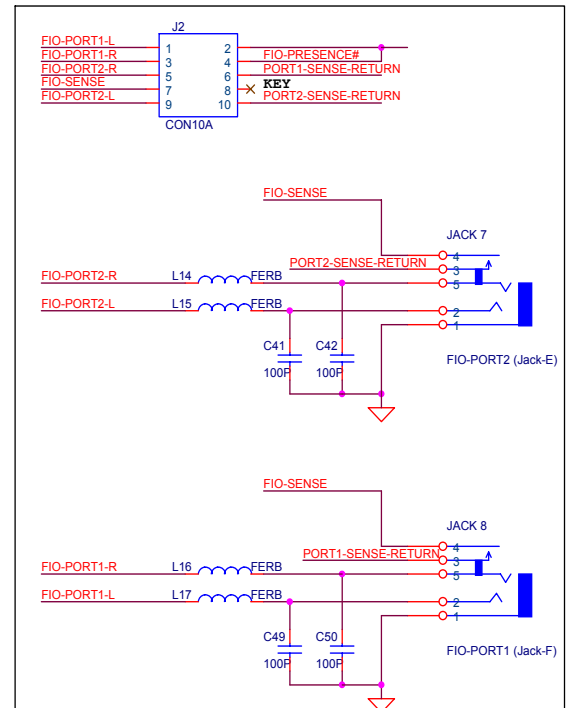

Figure 18. Onboard Front Panel Header Connection and Front Panel I/O

### 10.3. Analog Input/Output Connection

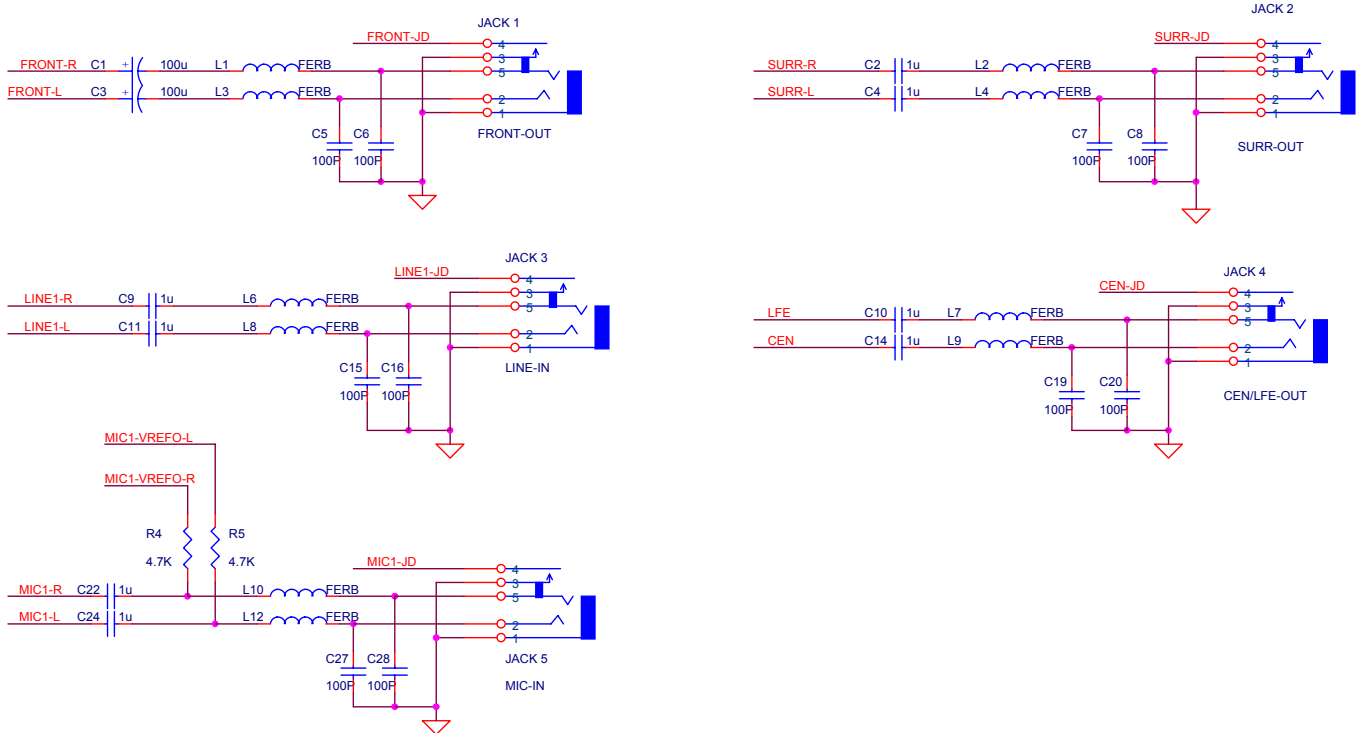

Figure 19. Analog Input/Output Connection

### 10.4. Optional S/PDIF Output

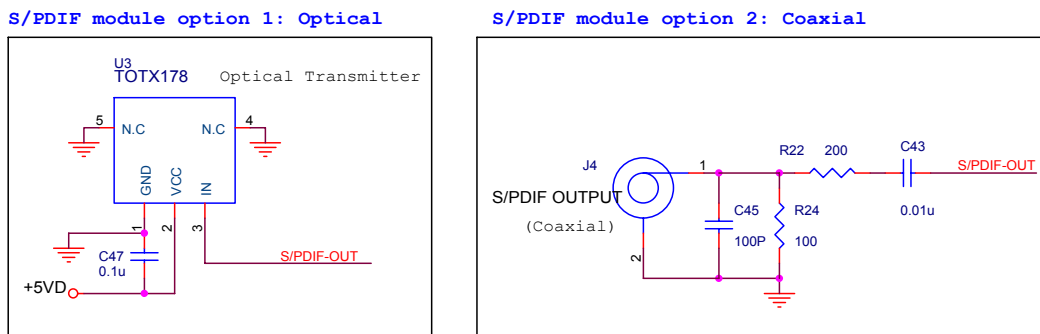
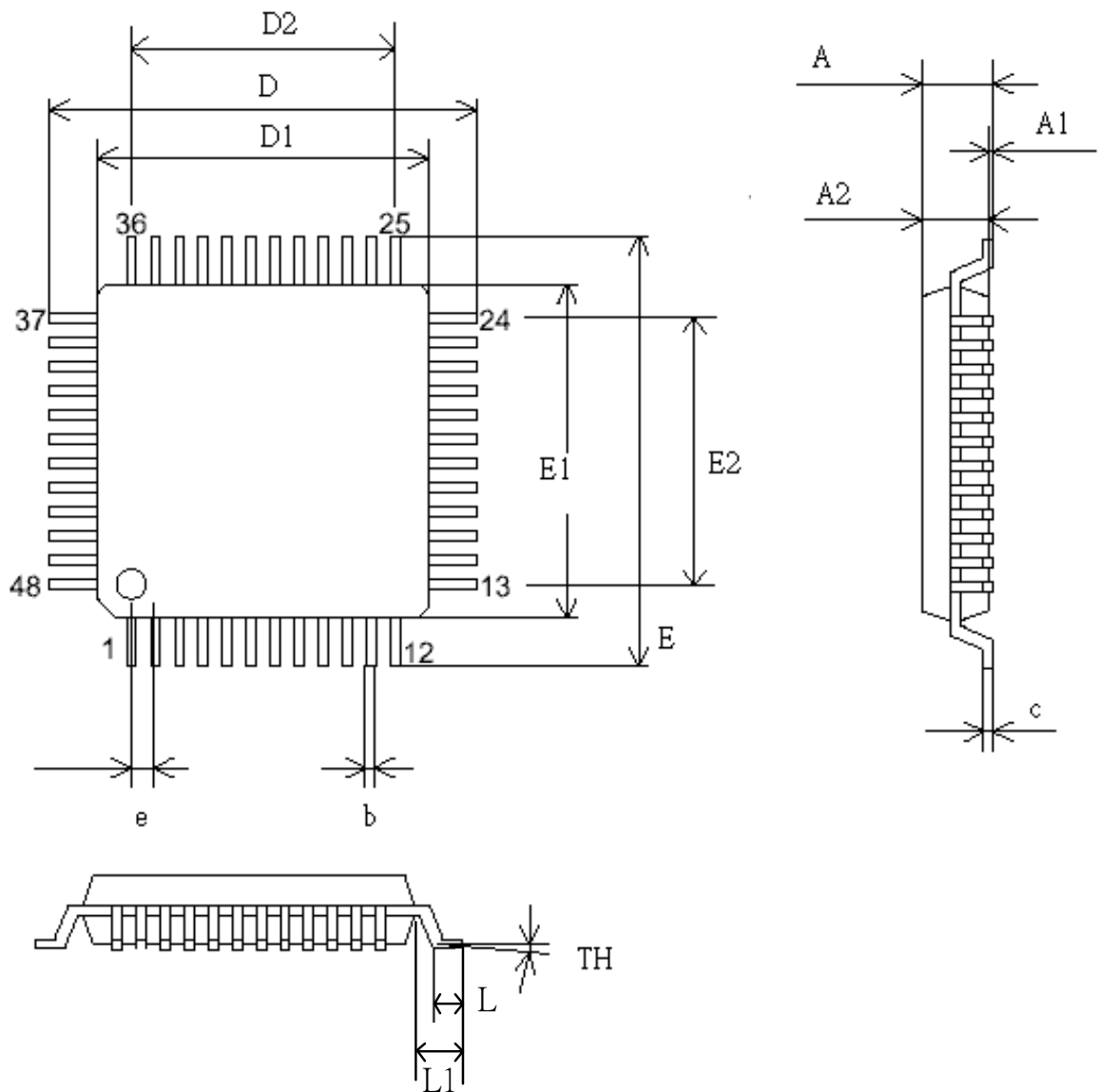

Figure 20. Optional S/PDIF Output

## 11. Mechanical Dimensions



See the Mechanical Dimensions notes on the next page.

### 11.1. Mechanical Dimensions Notes

SYMBOL	MILLIMETER			INCH		
	MIN.	TYP	MAX.	MIN.	TYP	MAX.
A	-	-	1.60	-	-	0.063
A1	0.05	-	0.15	0.002	-	0.006
A2	1.35	1.40	1.45	0.053	0.055	0.057
c	0.09	-	0.20	0.004	-	0.008
D	9.00 BSC			0.354 BSC		
D1	7.00 BSC			0.276 BSC		
D2	5.50			0.217		
E	9.00 BSC			0.354 BSC		
E1	7.00BSC			0.276 BSC		
E2	5.50			0.217		
b	0.17	0.20	0.27	0.007	0.008	0.011
e	0.50 BSC			0.0196 BSC		
TH	0°	3.5°	7°	0°	3.5°	7°
L	0.45	0.60	0.75	0.018	0.0236	0.030
L1	-	1.00	-	-	0.0393	-

TITLE: LQFP-48 (7.0x7.0x1.6mm) PACKAGE OUTLINE DRAWING, FOOTPRINT 2.0mm			
LEADFRAME MATERIAL			
APPROVE		DOC. NO.	
		VERSION	02
CHECK		DWG NO.	PKGC-065
		DATE	
REALTEK SEMICONDUCTOR CORP.			



## 12. Ordering Information

**Table 88. Ordering Information**

Part Number	Package	Status
ALC662-GR	LQFP-48 'Green' Package	Production
ALC662-VC-GR	ALC662-GR Version C Silicon	Production

*Note 1: See page 5 for Green package and version identification.*

*Note 2: Above parts are tested under AVDD=5.0V. If customers have lower AVDD request, please contact Realtek sales representatives or agents.*

---

**Realtek Semiconductor Corp.****Headquarters**

No. 2, Innovation Road II

Hsinchu Science Park, Hsinchu 300, Taiwan

Tel.: +886-3-578-0211. Fax: +886-3-557-6047

[www.realtek.com.tw](http://www.realtek.com.tw)